

Component Location

Engine Mounted Components, F-Series 250/550, Excursion and E-Series

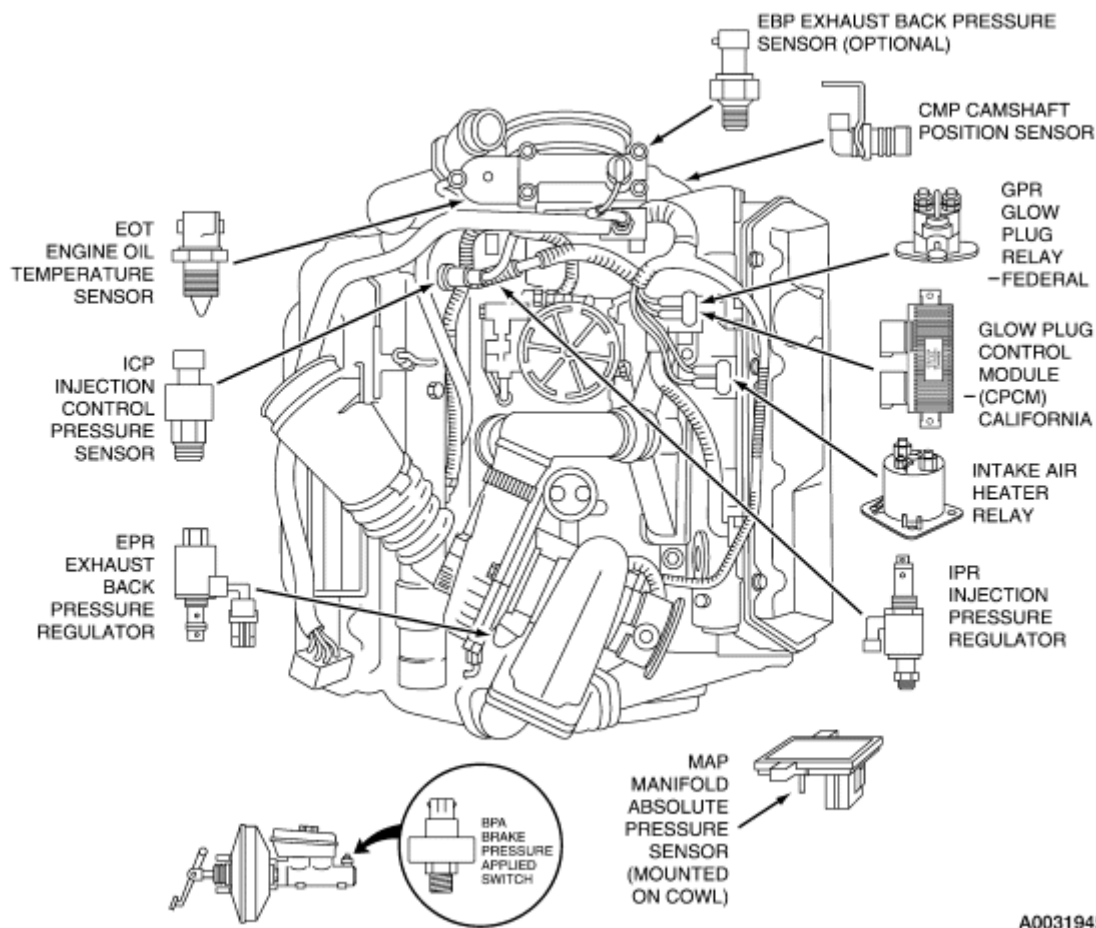

A0031945

Engine Mounted Components, F-Series 650/750

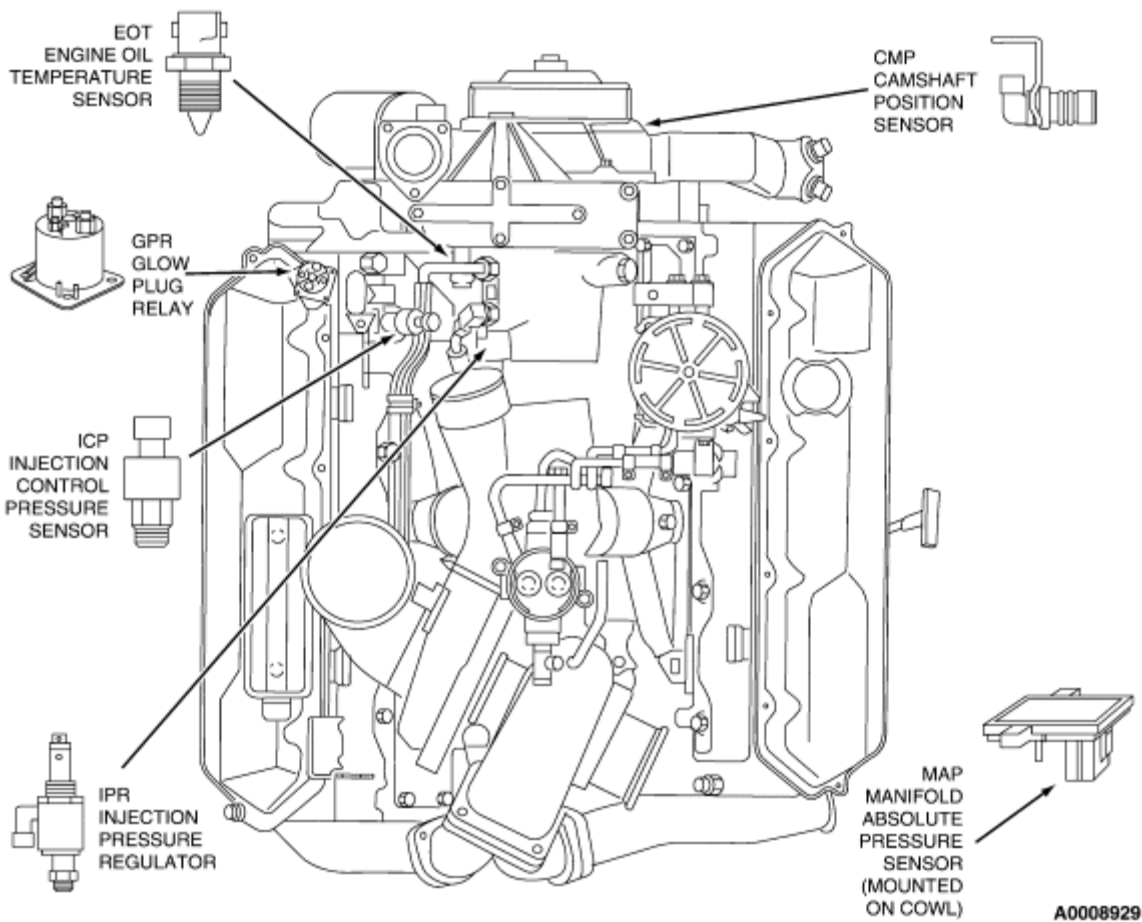

Switch Location — All Models, Except Parking Brake Applied (PBA) Switch for F-Series 650/750

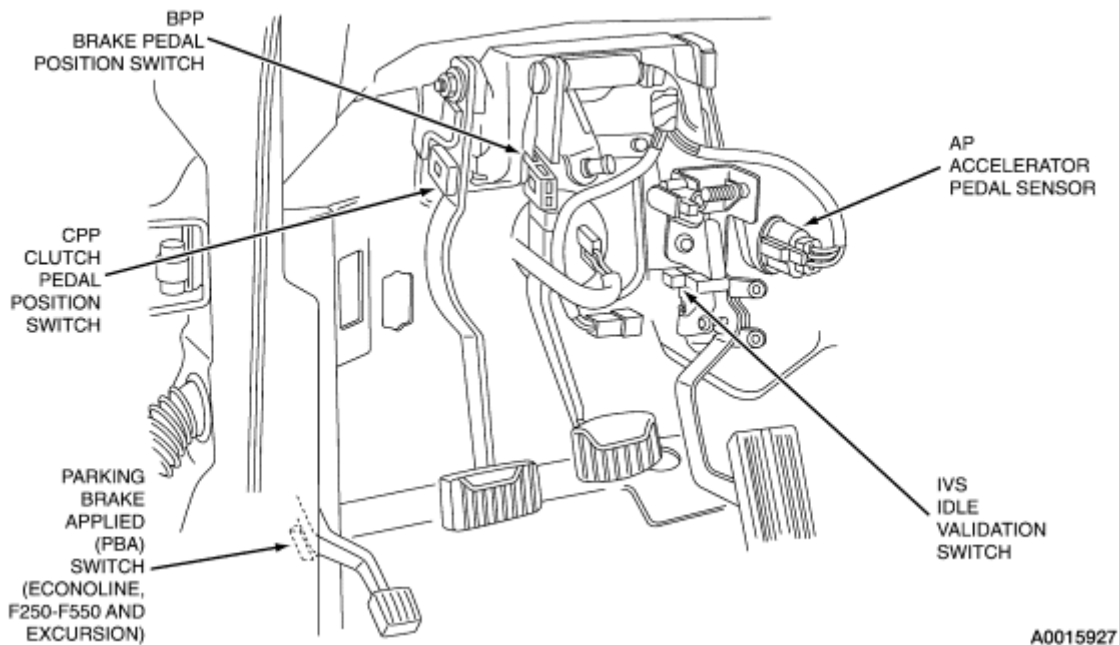

Barometric Pressure (BARO) Sensor

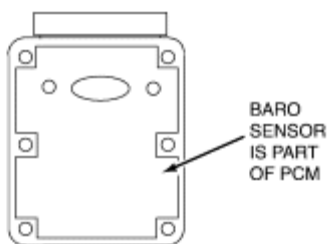

A0011109

Switch Location — Parking Brake Applied (PBA) Switch, F-Series650/750

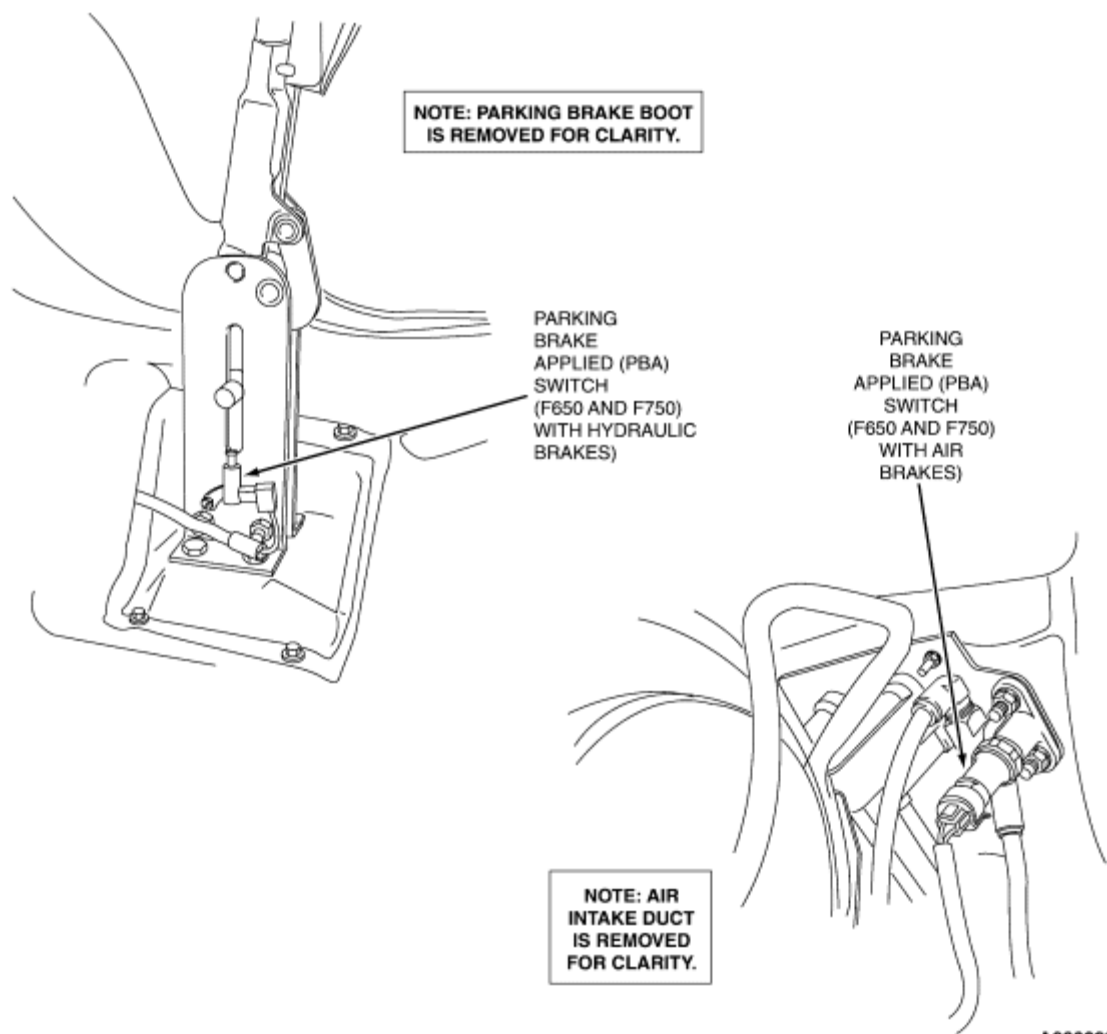

A0008930

Downshift Solenoid — F-Series 650/750 with Allison AT545 Automatic Transmission

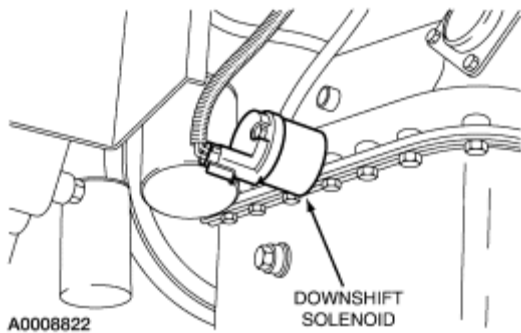

Brake Pressure Applied Switch — F-Series 650/750 with Hydraulic Brakes

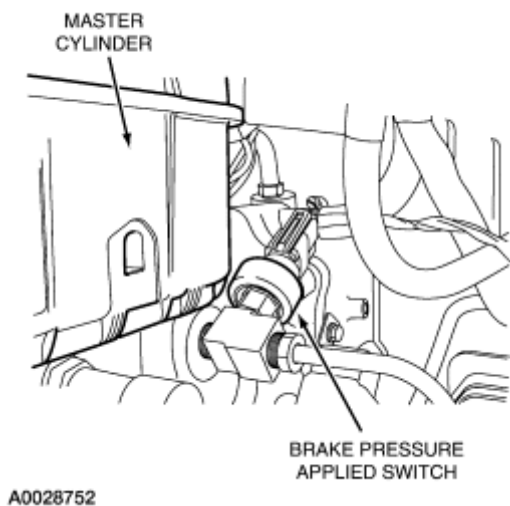

Brake Pressure Applied Switch — F-Series 650/750 with Air Brakes

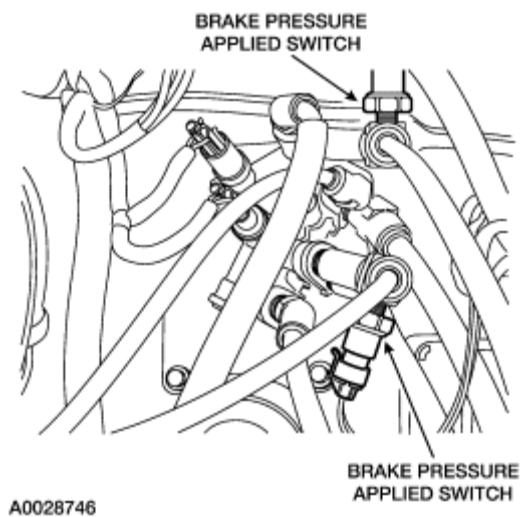

Electronic Throttle Control

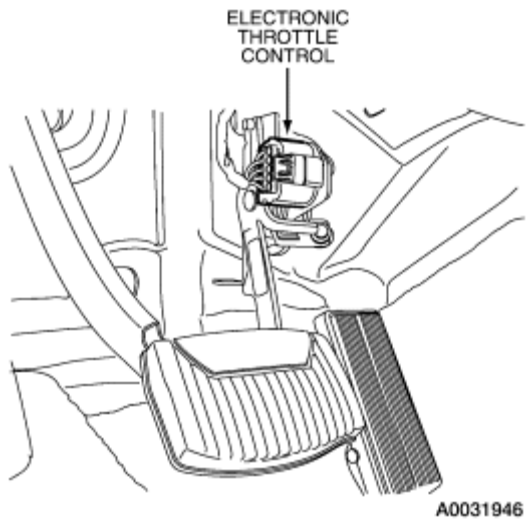

Relays — F-Series 650/750

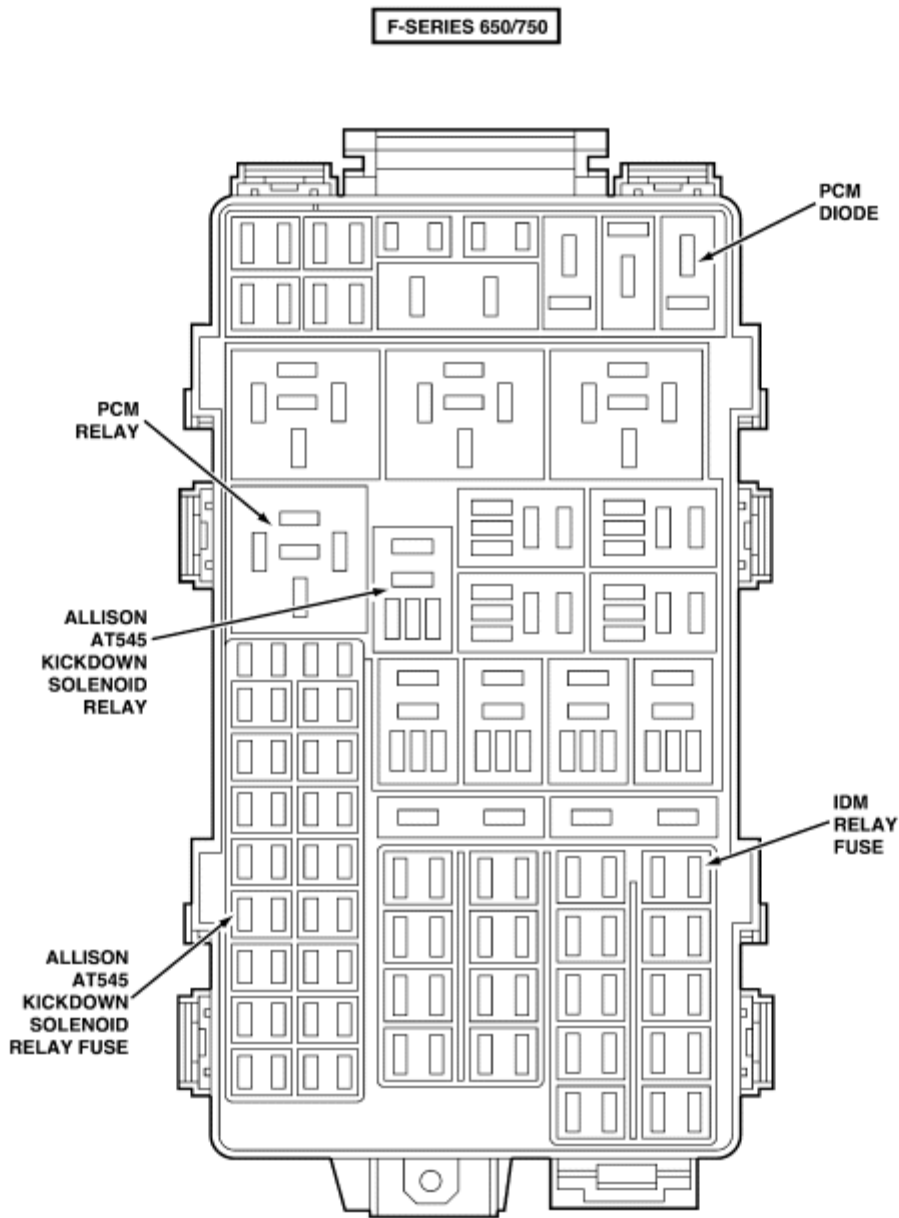

A0010822

Neutral Switch — F-Series 650/750 with Allison Transmission

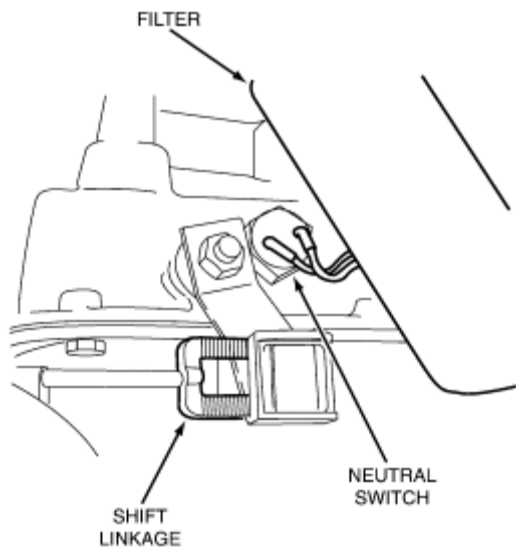

A0008943

Injector Drive Module (IDM) Relay, F-Series 650/750

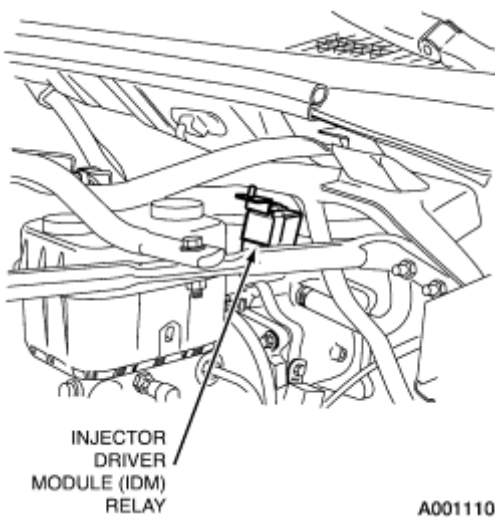

A0011108

