



# POWER DISTRIBUTION 13-2

2001 EXCURSION, SUPER DUTY SERIES F-250, F-350, F-450, F-550

\* JOB 1 + 90

EXCURSION

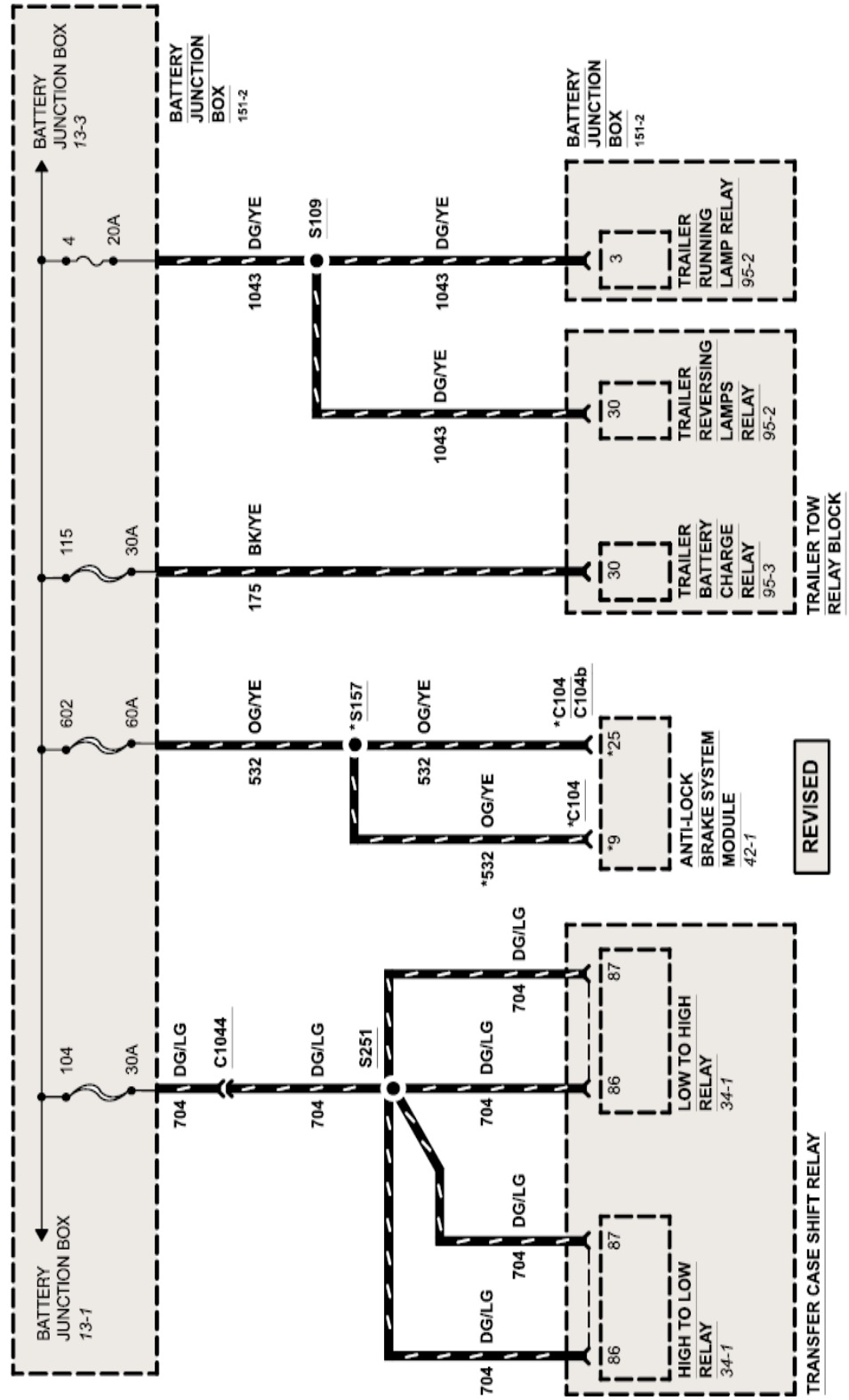

REVISED

# 13-3 POWER DISTRIBUTION

2001 EXCURSION, SUPER DUTY SERIES F-250, F-350, F-450, F-550

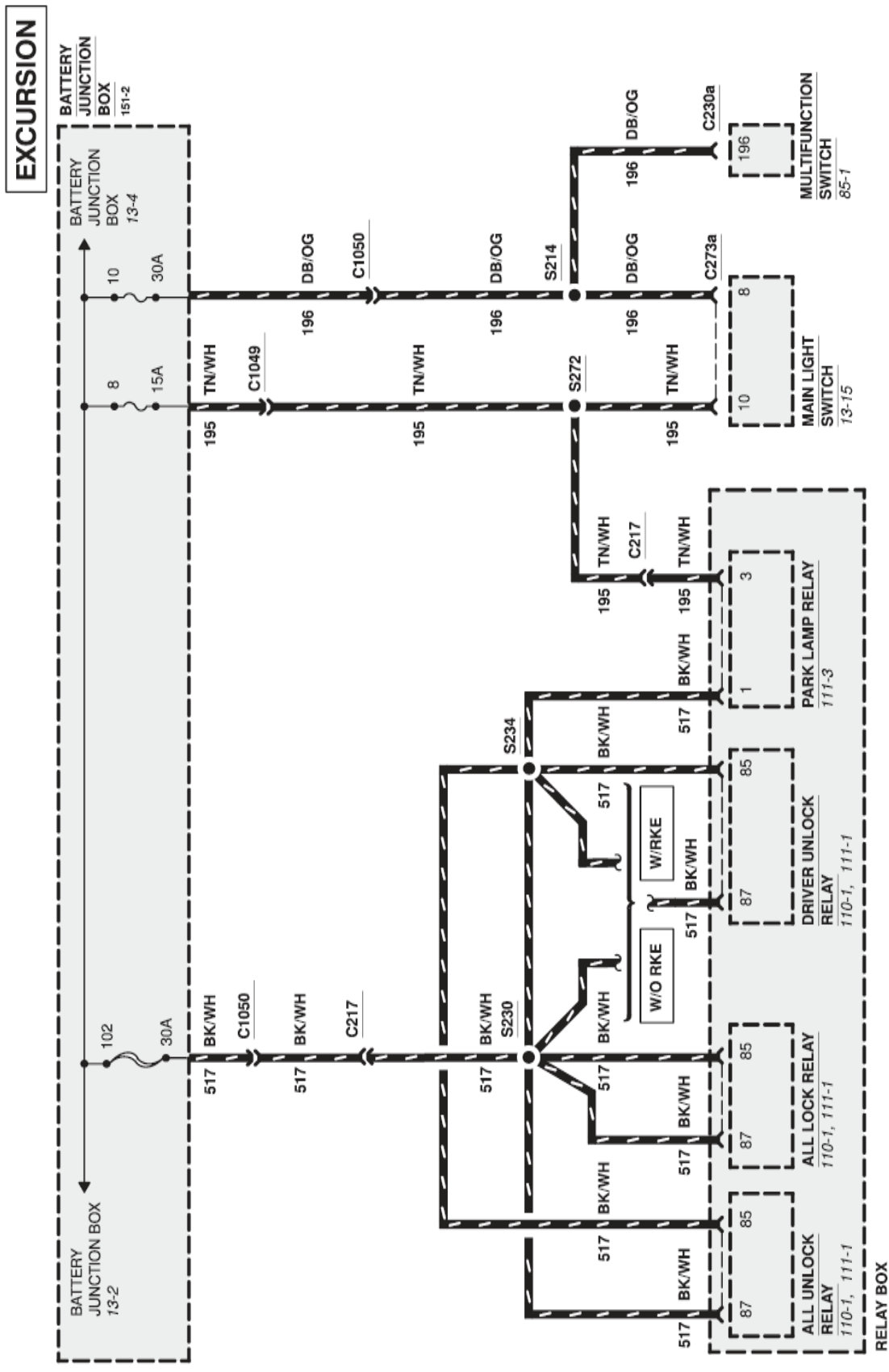



# 13-5 POWER DISTRIBUTION

2001 EXCURSION, SUPER DUTY SERIES F-250, F-350, F-450, F-550

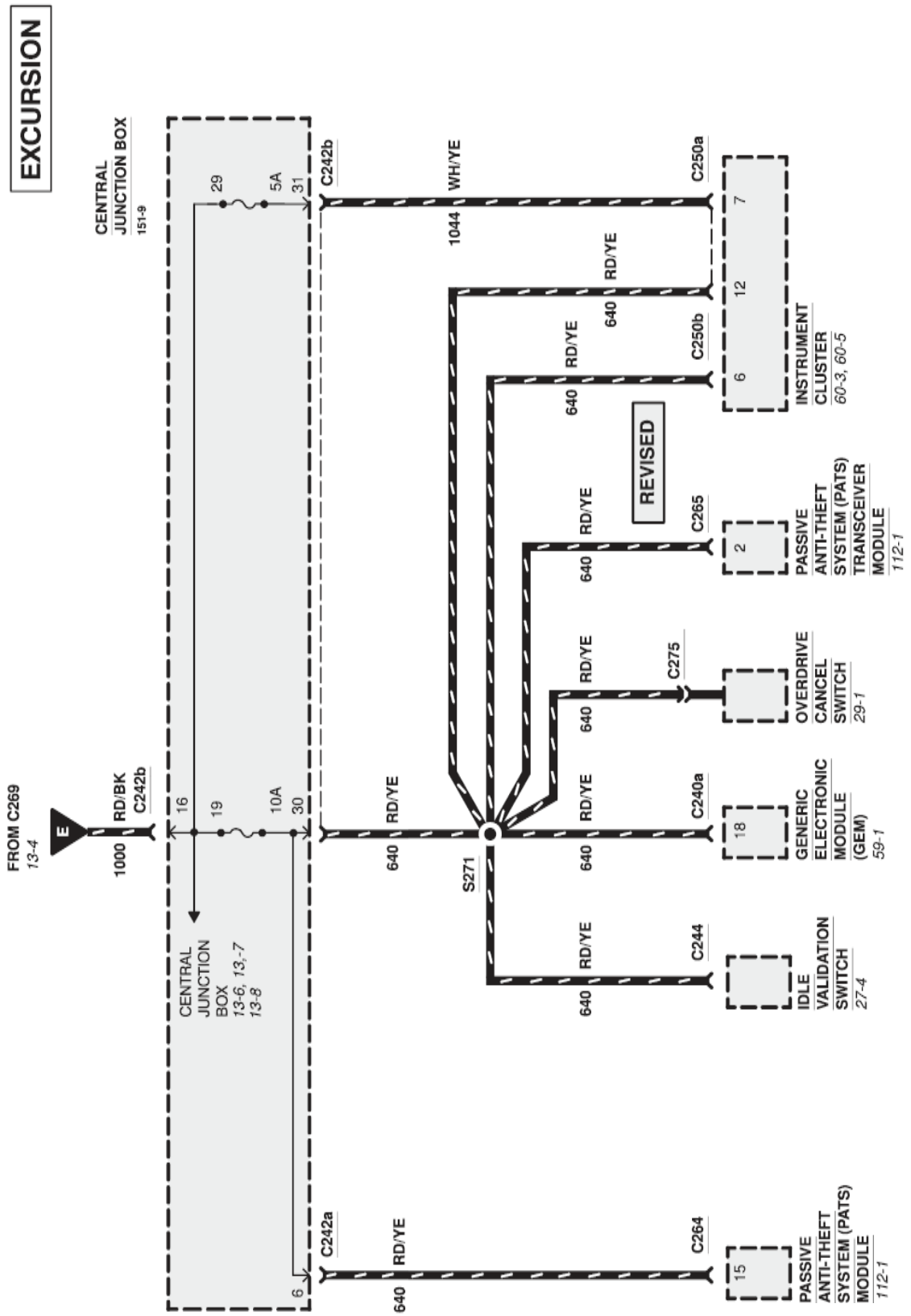

# POWER DISTRIBUTION 13-6

2001 EXCURSION, SUPER DUTY SERIES F-250, F-350, F-450, F-550

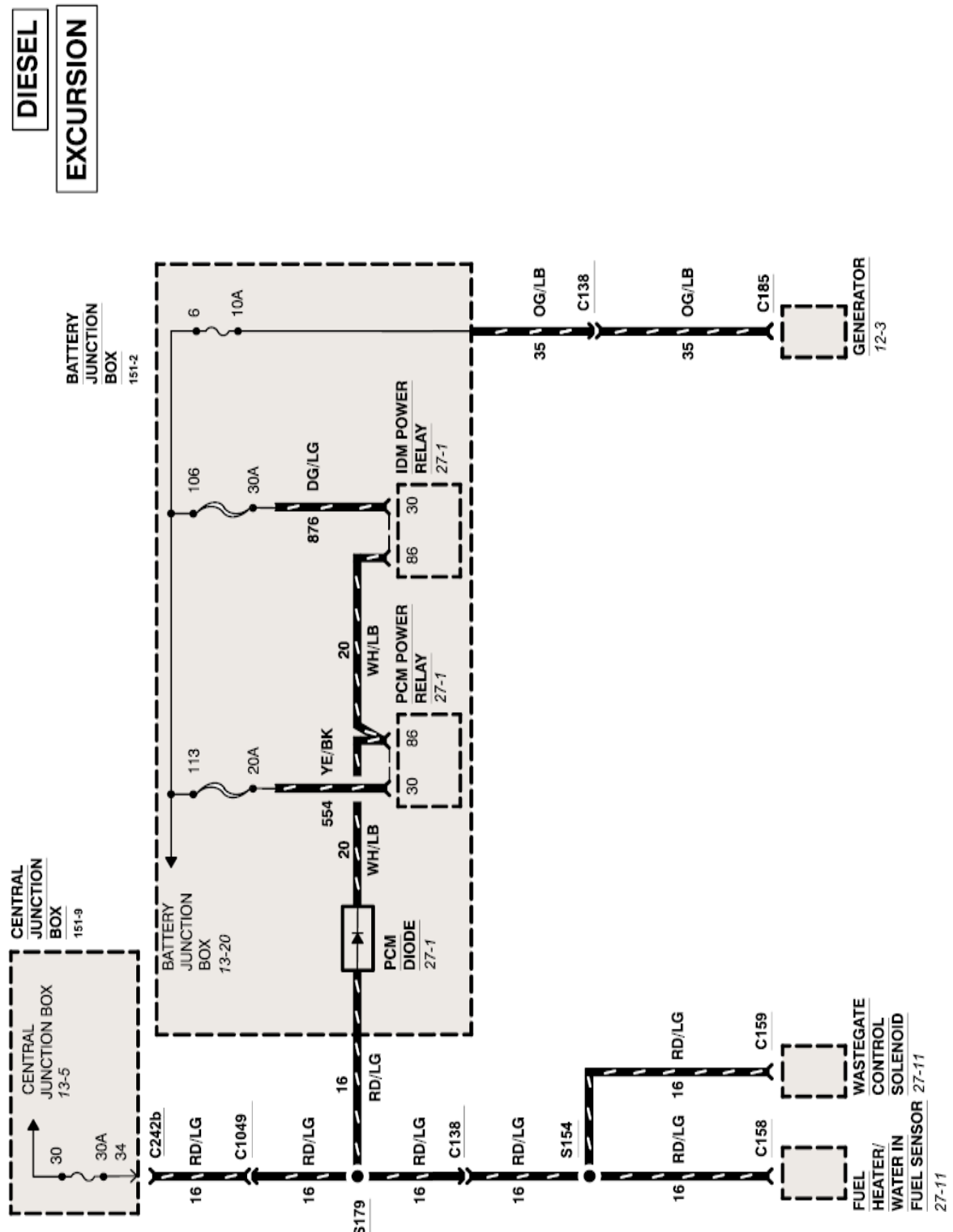

# 13-7 POWER DISTRIBUTION

2001 EXCURSION, SUPER DUTY SERIES F-250, F-350, F-450, F-550

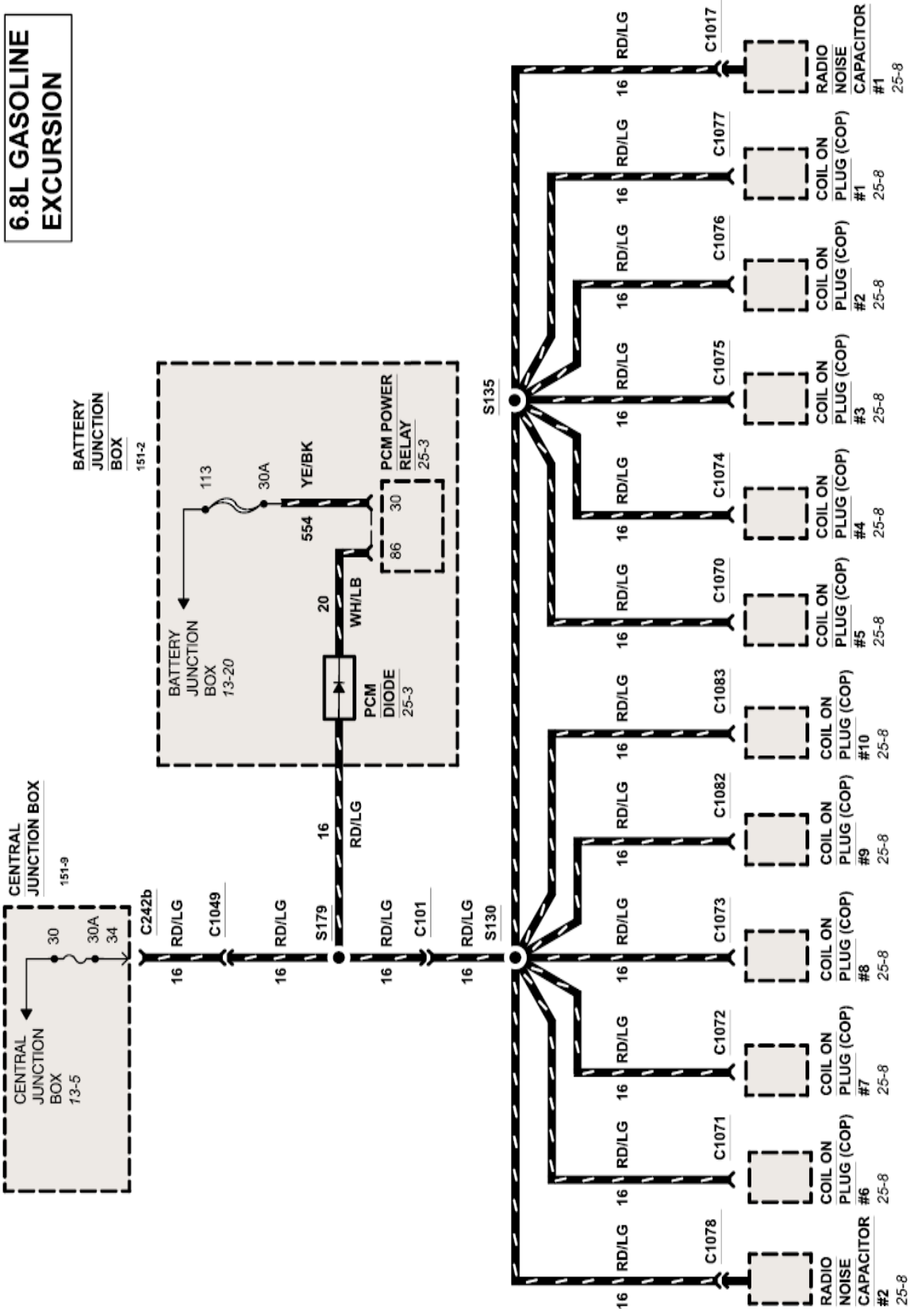

# POWER DISTRIBUTION 13-8

2001 EXCURSION, SUPER DUTY SERIES F-250, F-350, F-450, F-550

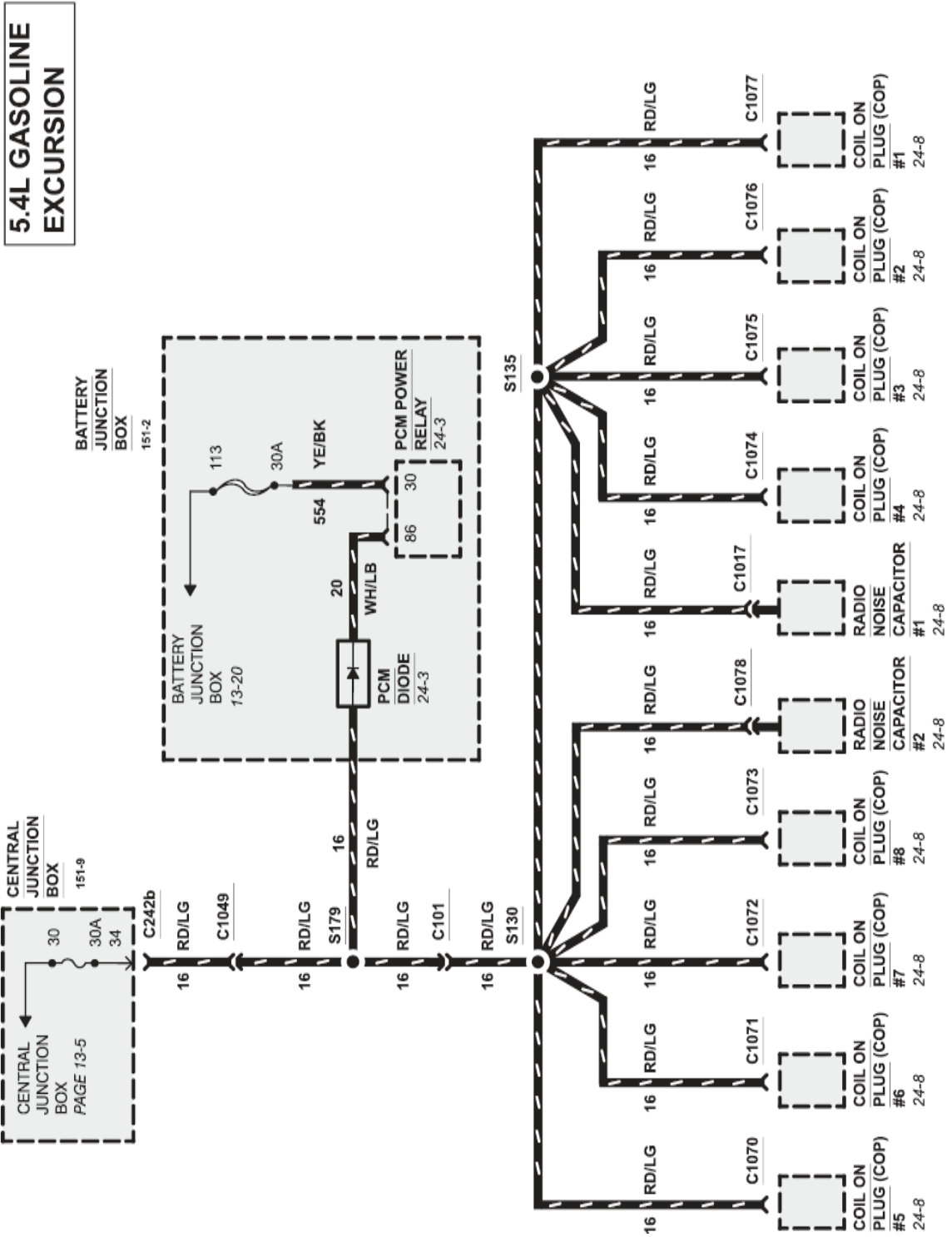



# 13-9 POWER DISTRIBUTION

2001 EXCURSION, SUPER DUTY SERIES F-250, F-350, F-450, F-550

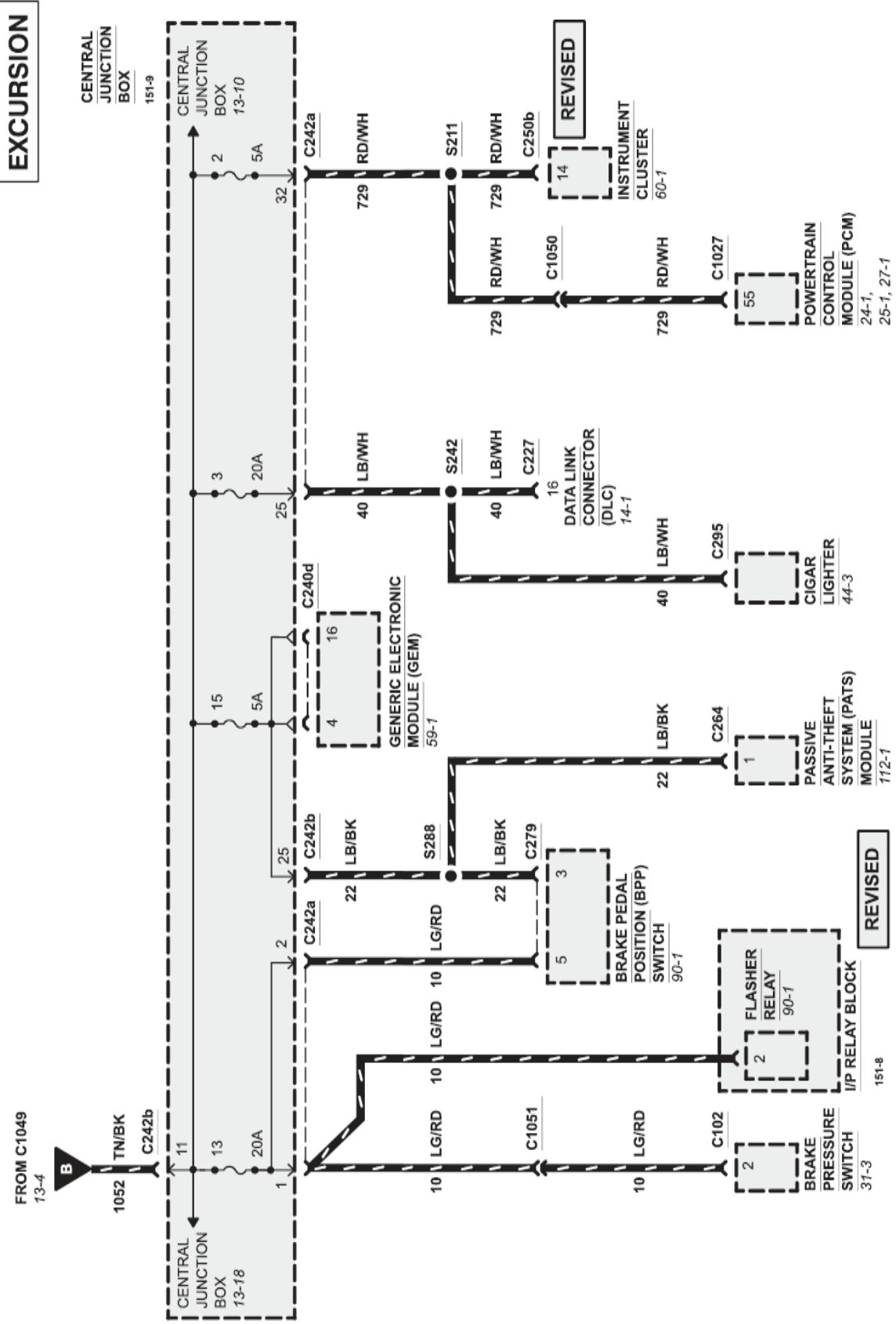

# POWER DISTRIBUTION 13-10

2001 EXCURSION, SUPER DUTY SERIES F-250, F-350, F-450, F-550

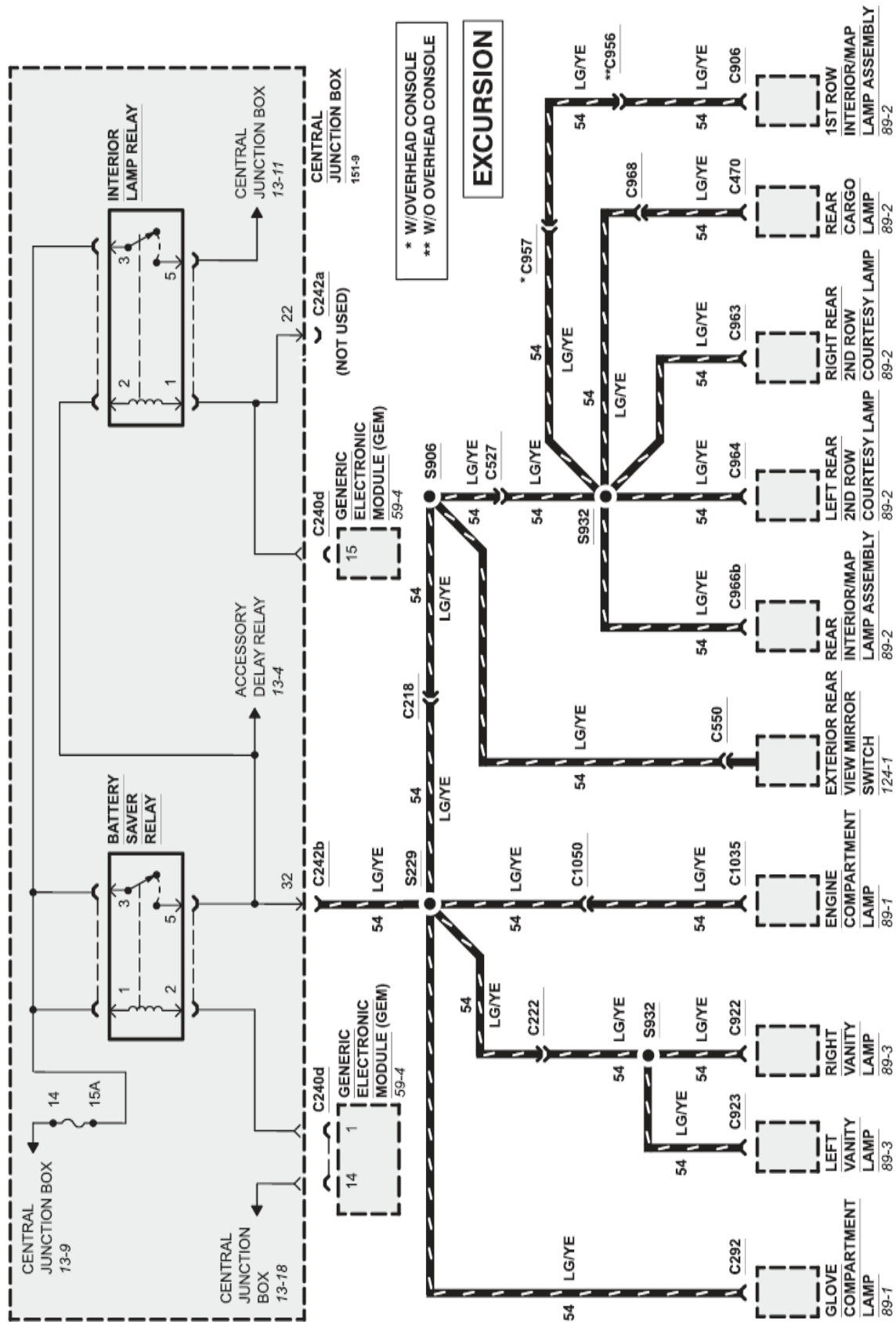

# 13-11 POWER DISTRIBUTION

2001 EXCURSION, SUPER DUTY SERIES F-250, F-350, F-450, F-550

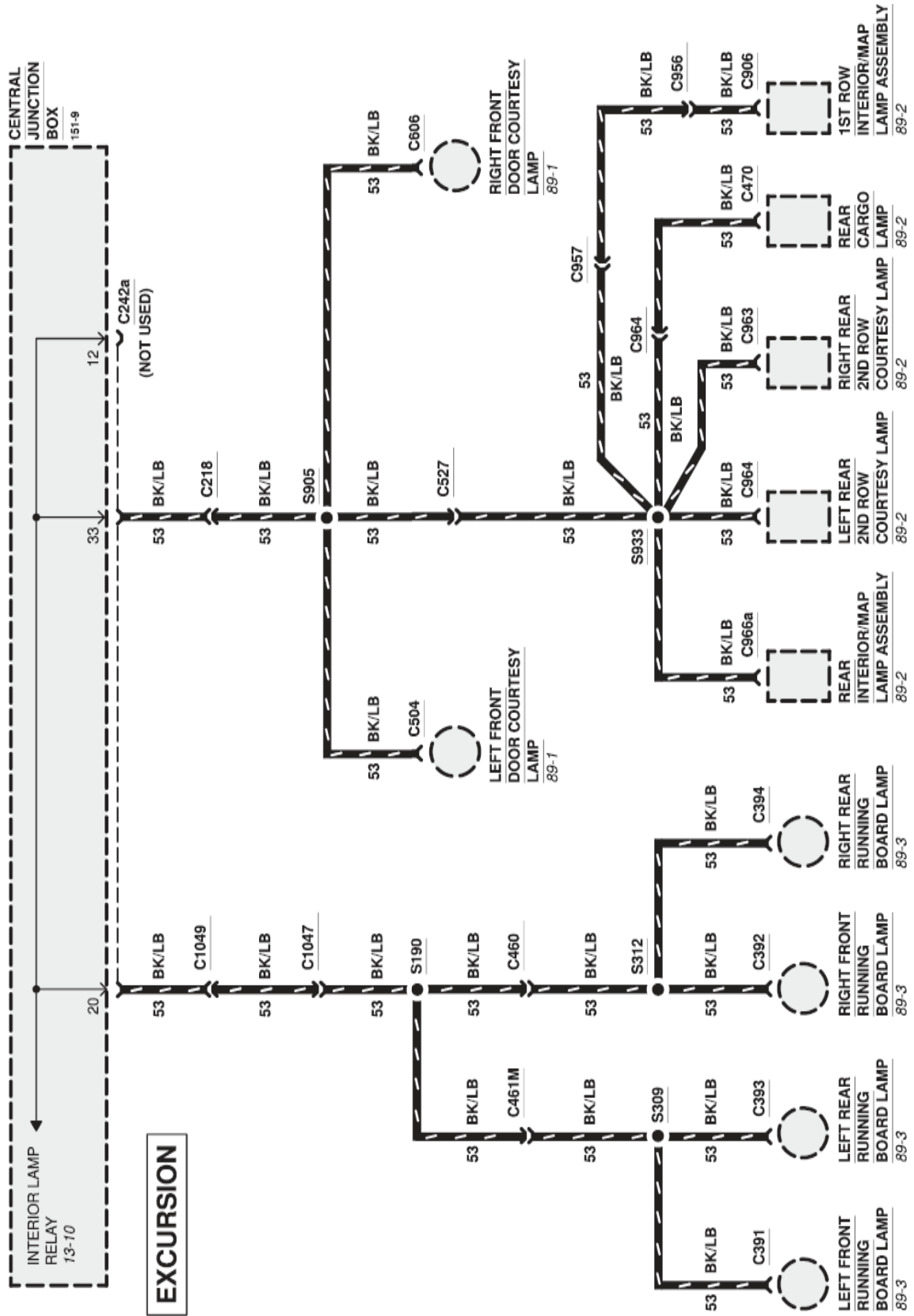

# POWER DISTRIBUTION 13-12

2001 EXCURSION, SUPER DUTY SERIES F-250, F-350, F-450, F-550

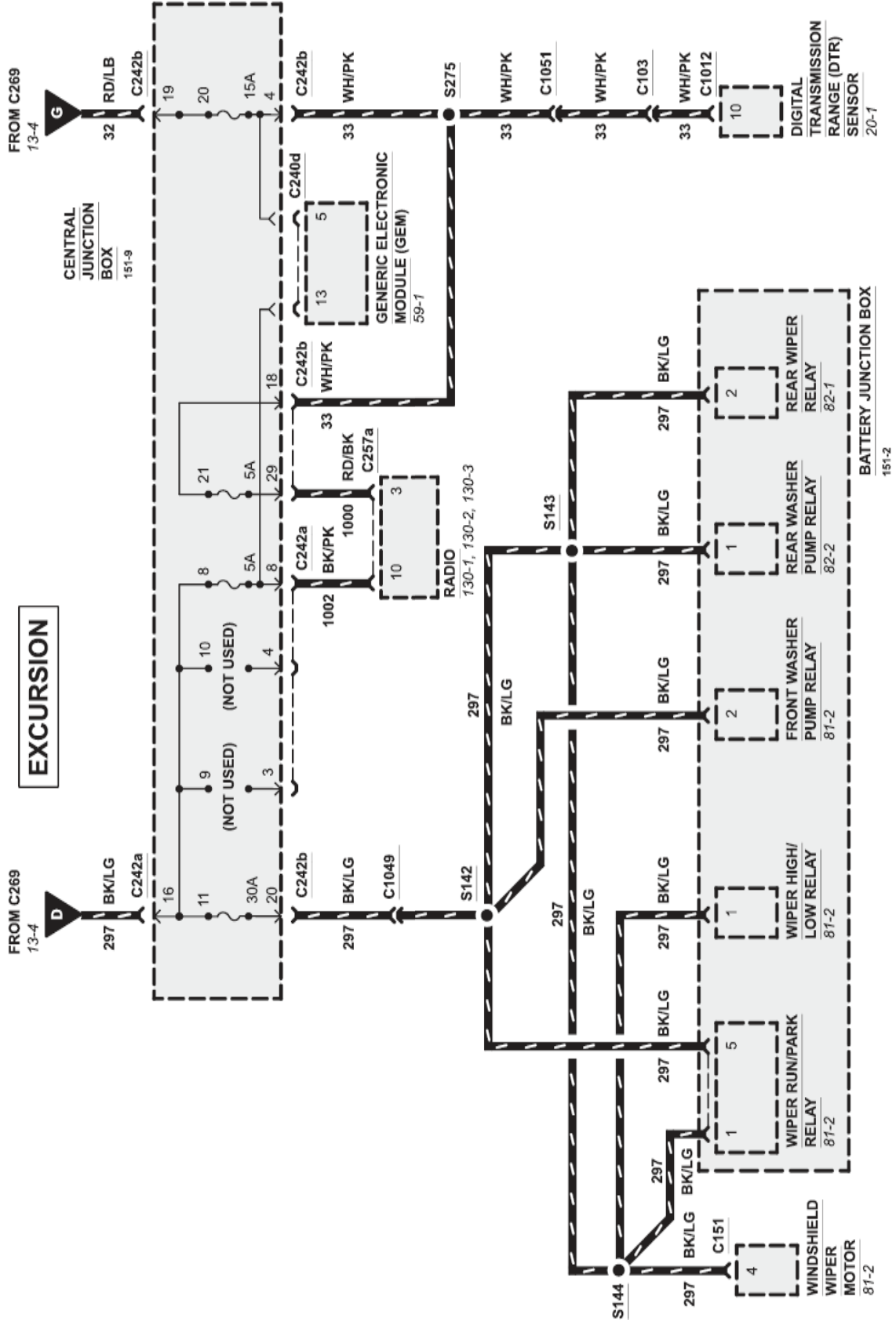

# 13-13 POWER DISTRIBUTION

2001 EXCURSION, SUPER DUTY SERIES F-250, F-350, F-450, F-550

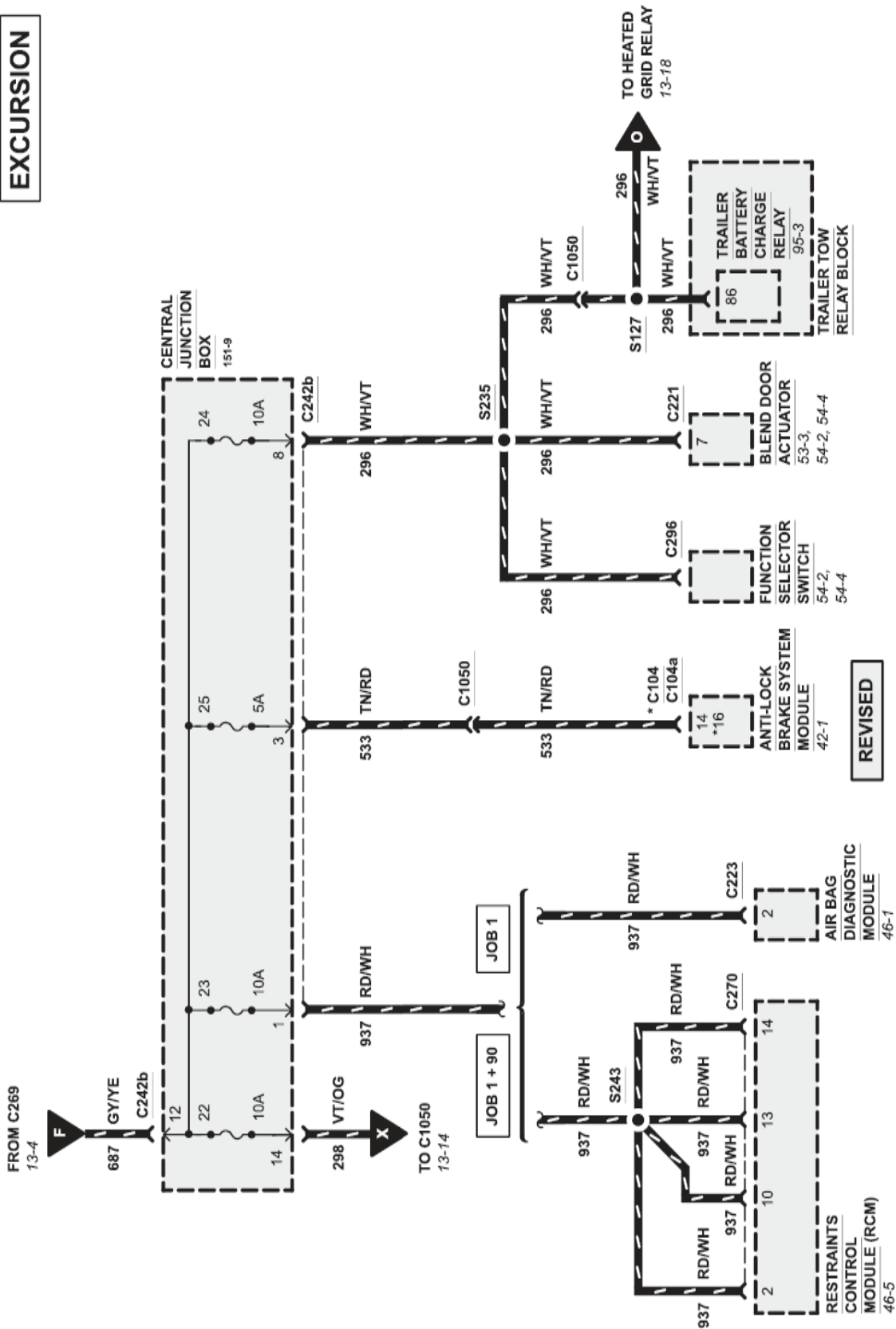

# POWER DISTRIBUTION 13-14

2001 EXCURSION, SUPER DUTY SERIES F-250, F-350, F-450, F-550

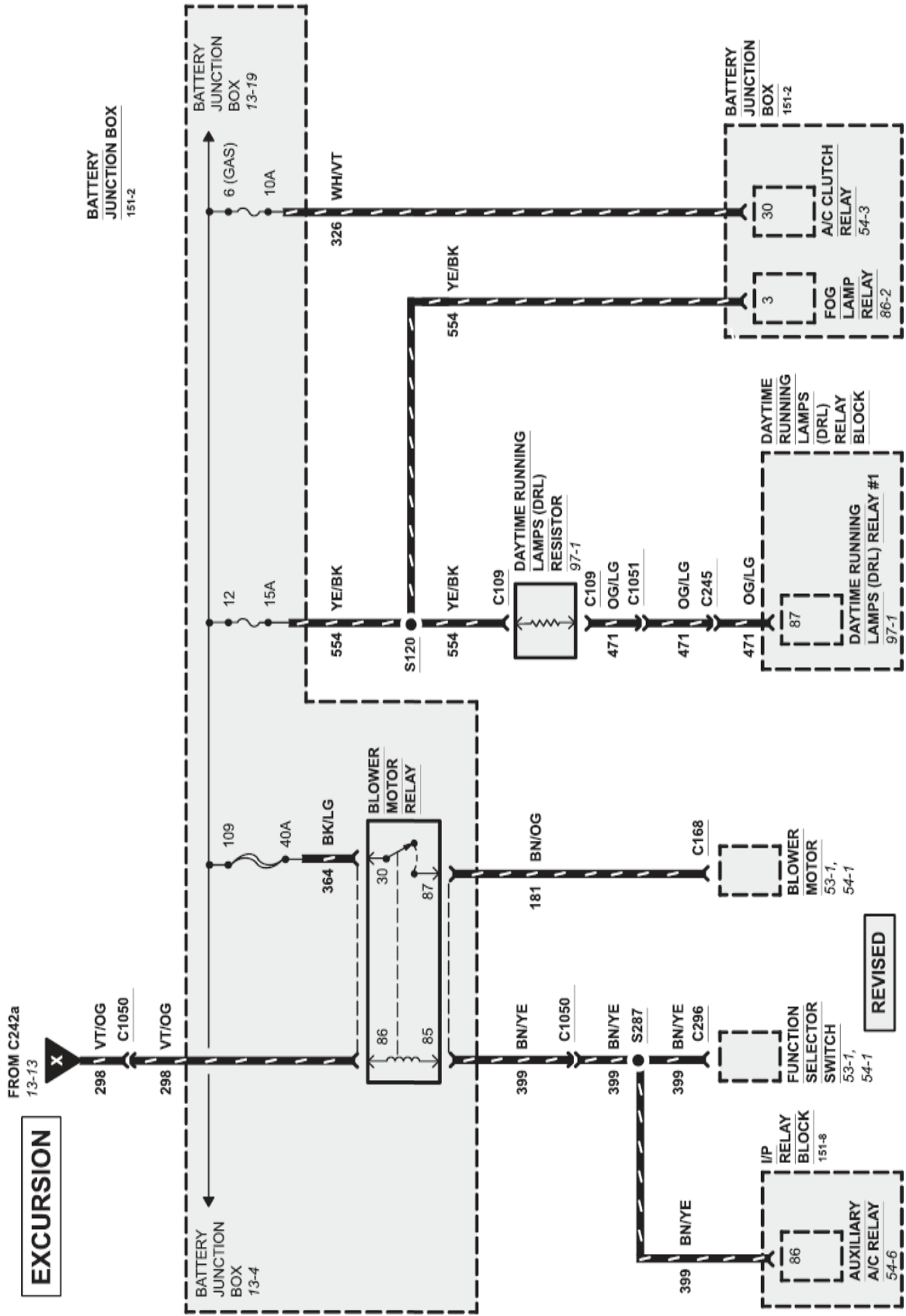

# 13-15 POWER DISTRIBUTION

2001 EXCURSION, SUPER DUTY SERIES F-250, F-350, F-450, F-550

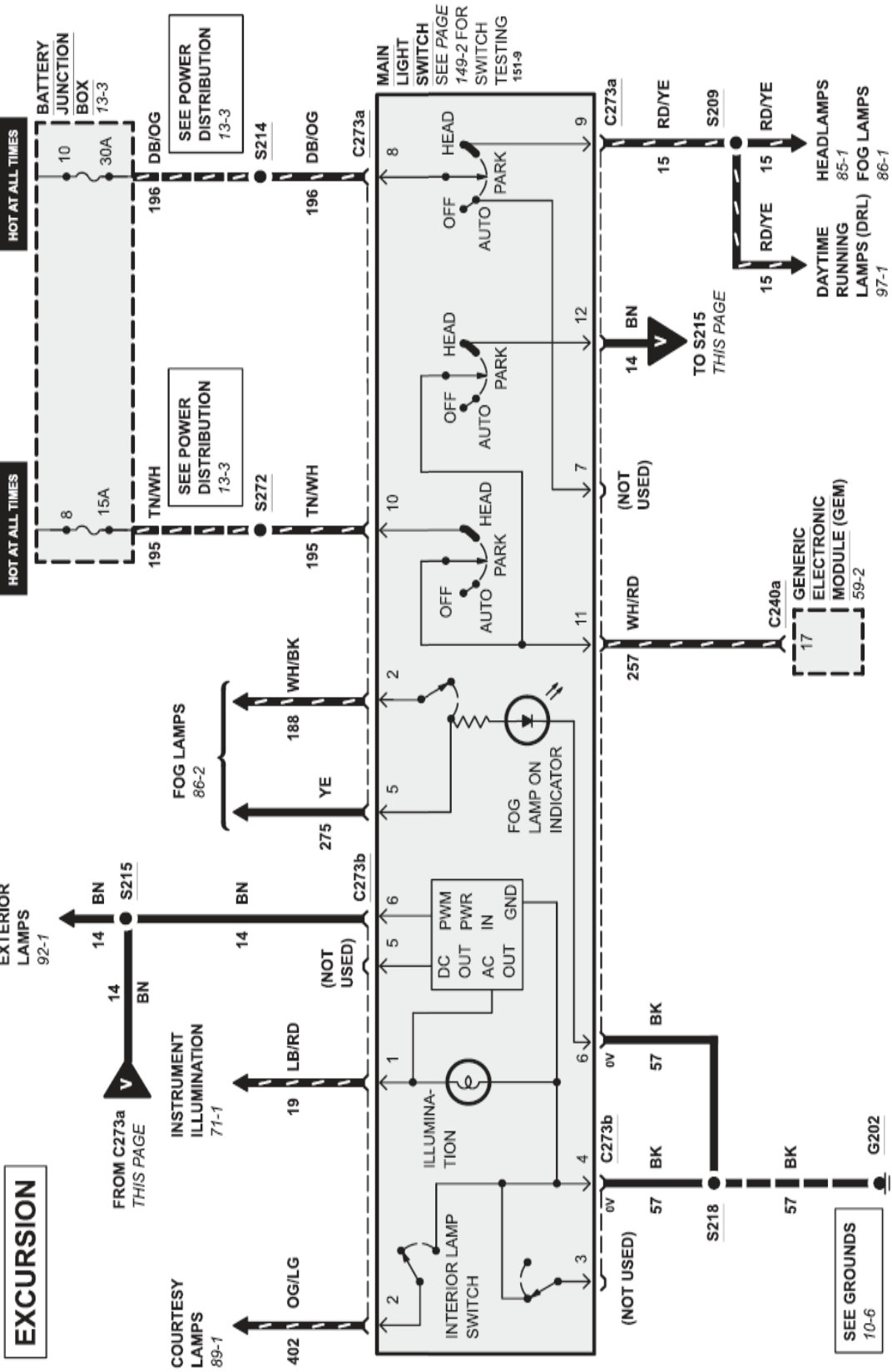

# POWER DISTRIBUTION 13-16

2001 EXCURSION, SUPER DUTY SERIES F-250, F-350, F-450, F-550

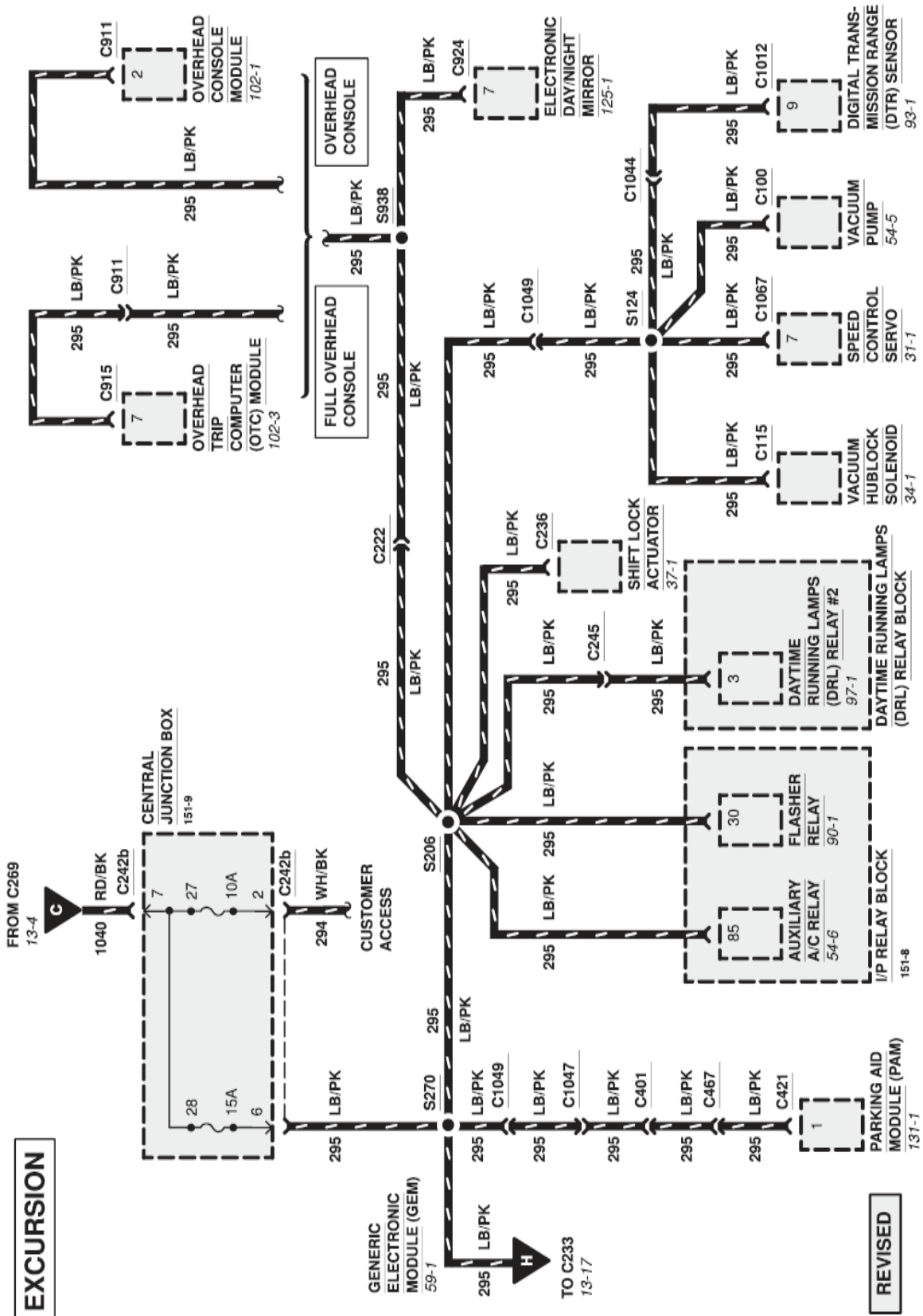



# 13-17 POWER DISTRIBUTION

2001 EXCURSION, SUPER DUTY SERIES F-250, F-350, F-450, F-550

## EXCURSION

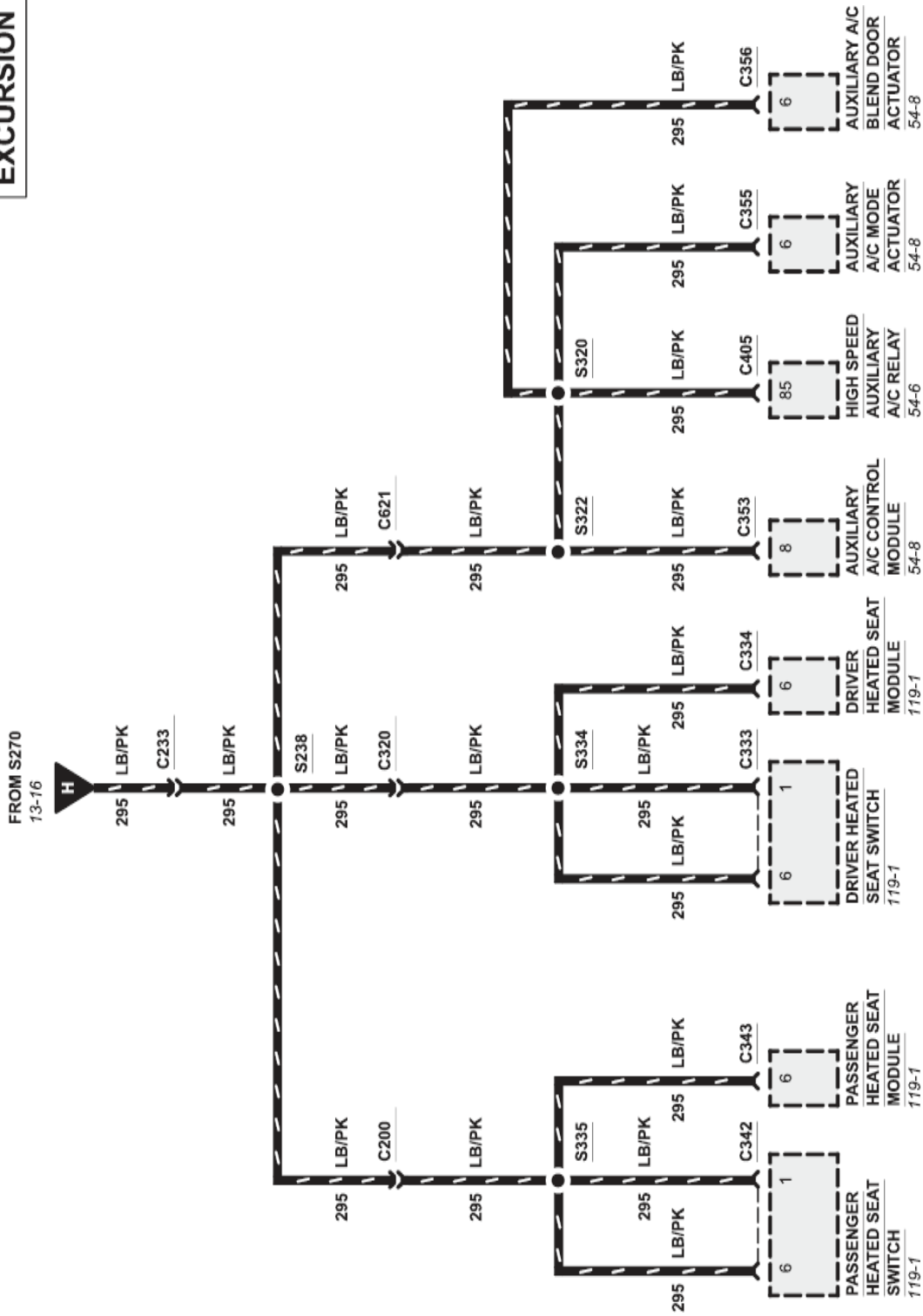



# 13-19 POWER DISTRIBUTION

2001 EXCURSION, SUPER DUTY SERIES F-250, F-350, F-450, F-550

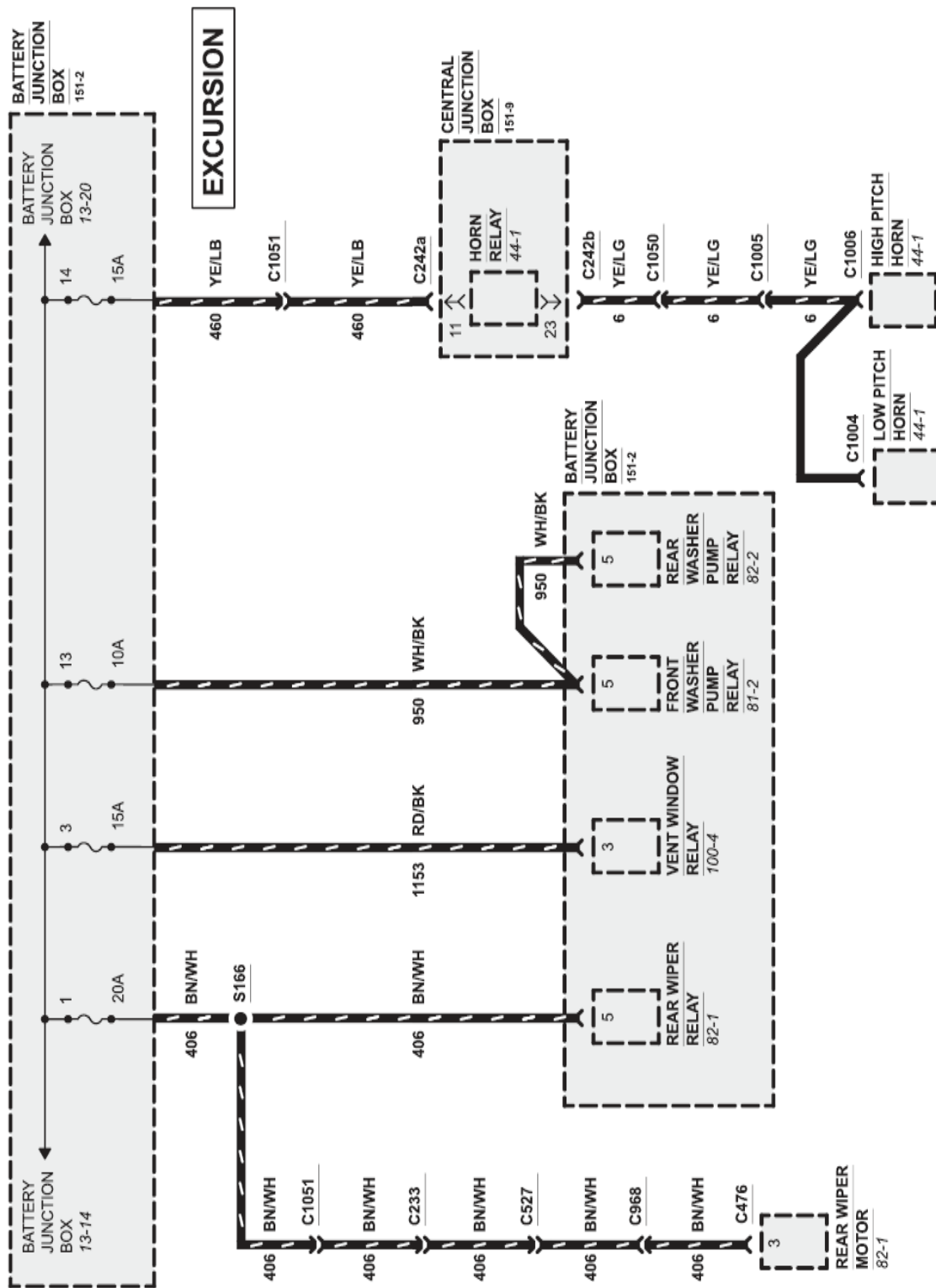



# 13-21 POWER DISTRIBUTION

2001 EXCURSION, SUPER DUTY SERIES F-250, F-350, F-450, F-550

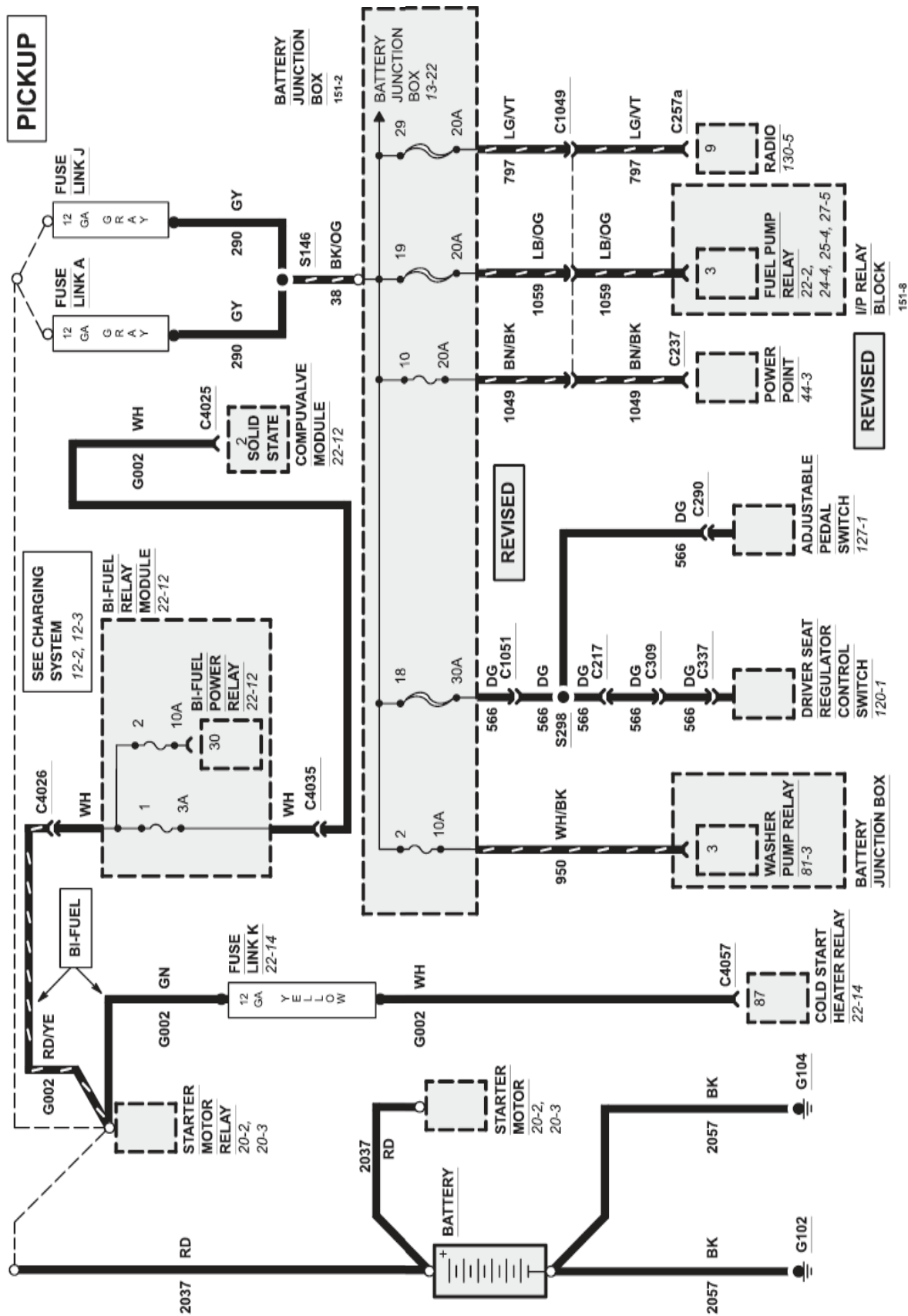

# POWER DISTRIBUTION 13-22

2001 EXCURSION, SUPER DUTY SERIES F-250, F-350, F-450, F-550

**PICKUP**

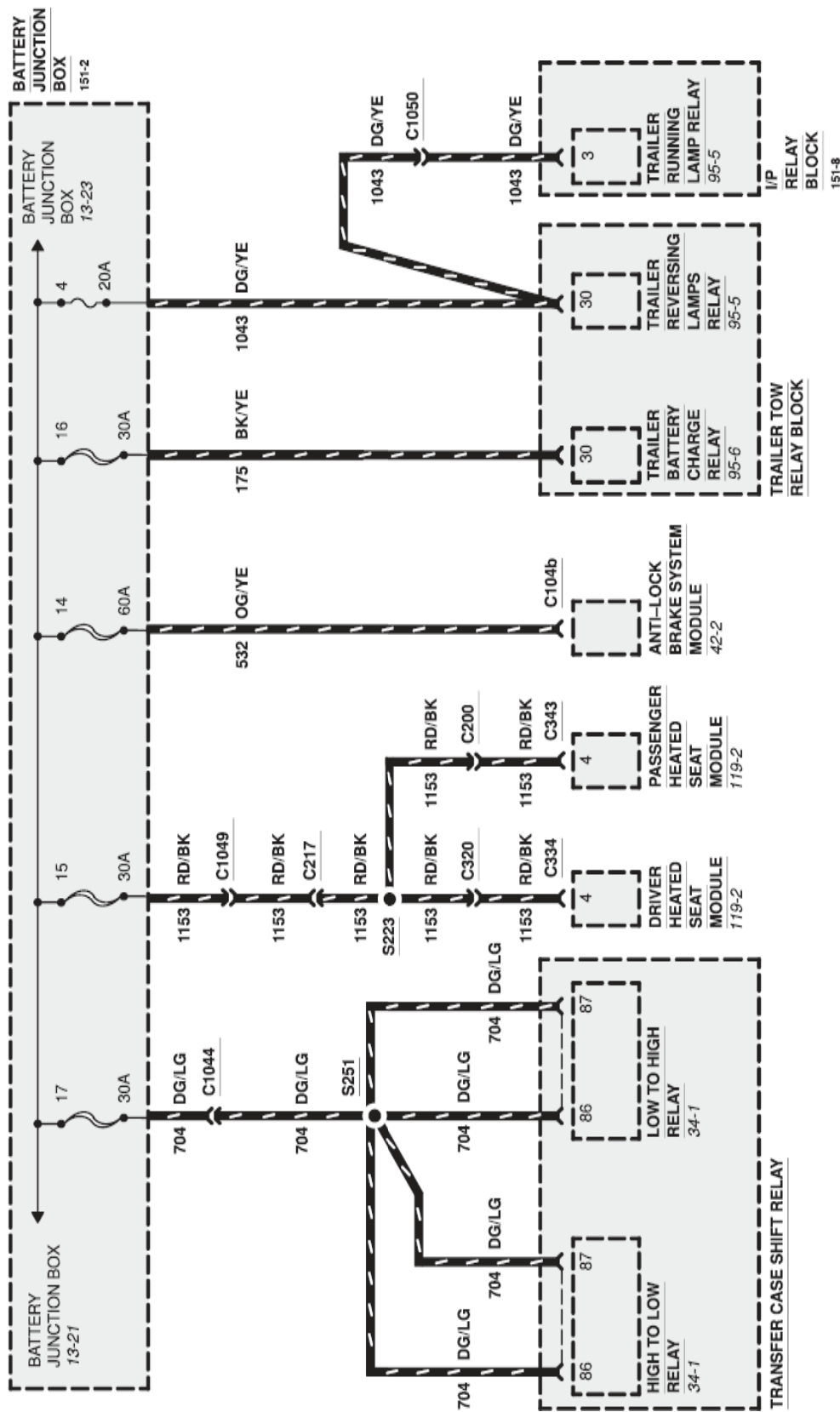

**REVISED**

# 13-23 POWER DISTRIBUTION

2001 EXCURSION, SUPER DUTY SERIES F-250, F-350, F-450, F-550

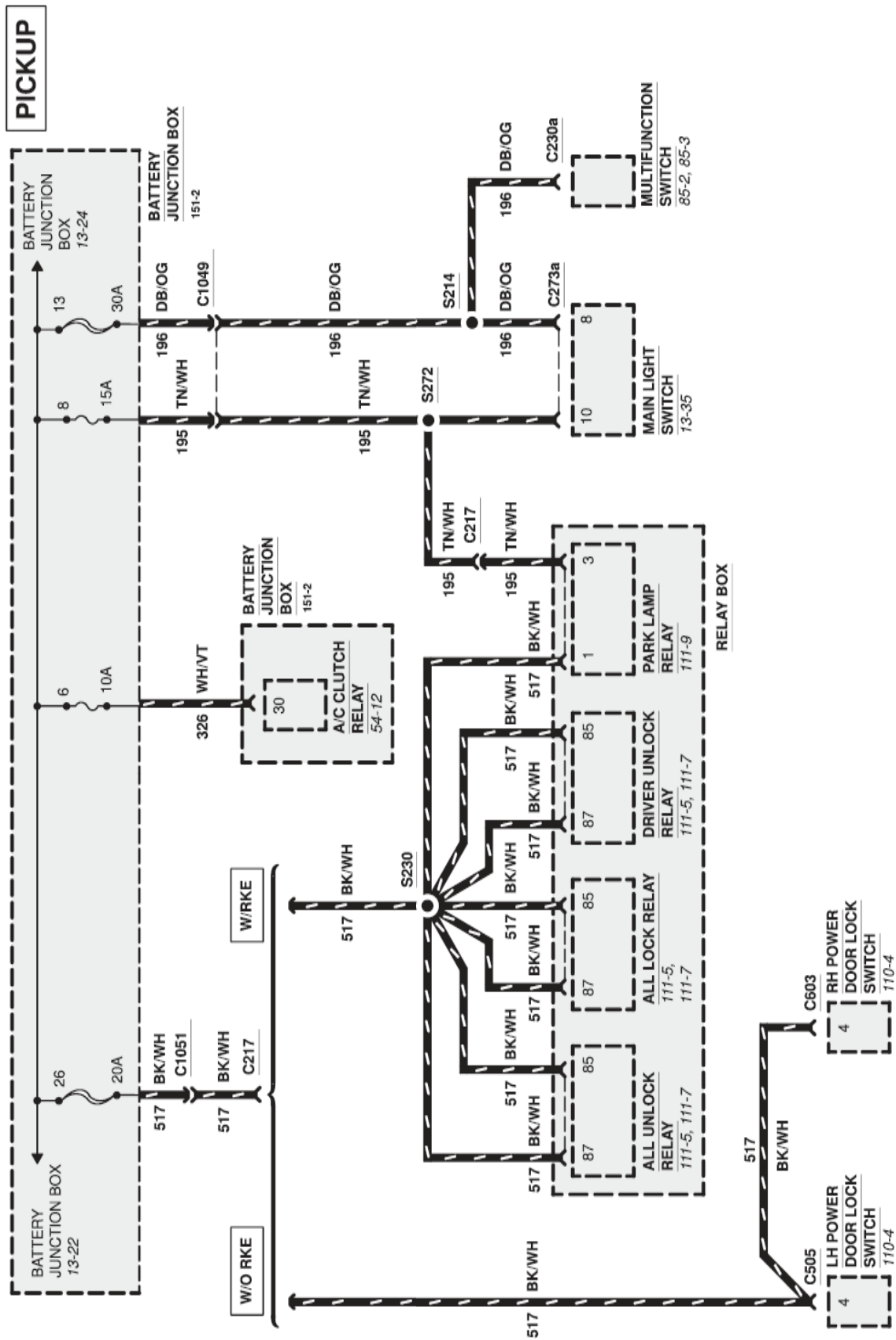

# POWER DISTRIBUTION 13-24

2001 EXCURSION, SUPER DUTY SERIES F-250, F-350, F-450, F-550

PICKUP

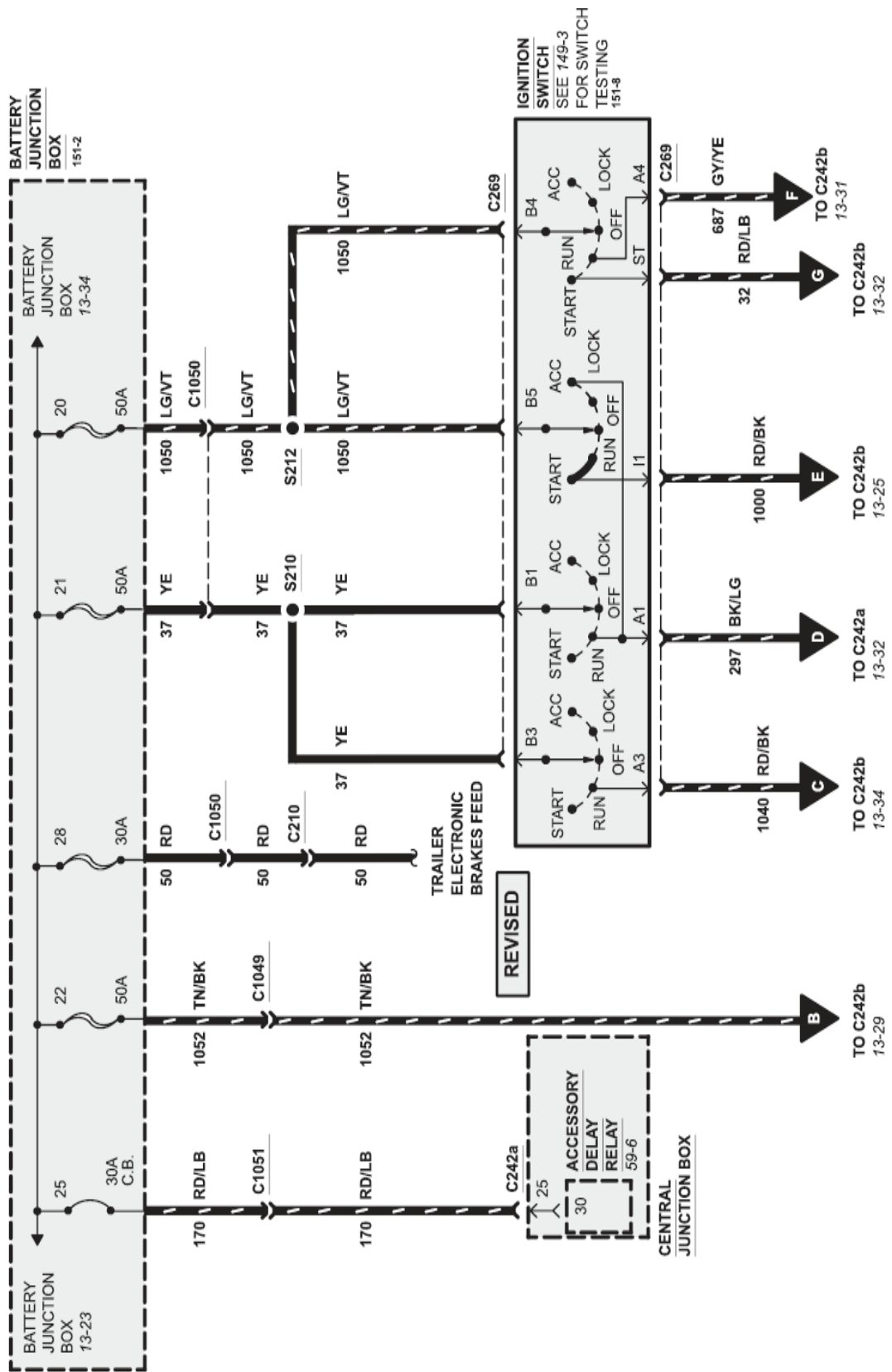



# 13-25 POWER DISTRIBUTION

2001 EXCURSION, SUPER DUTY SERIES F-250, F-350, F-450, F-550

PICKUP

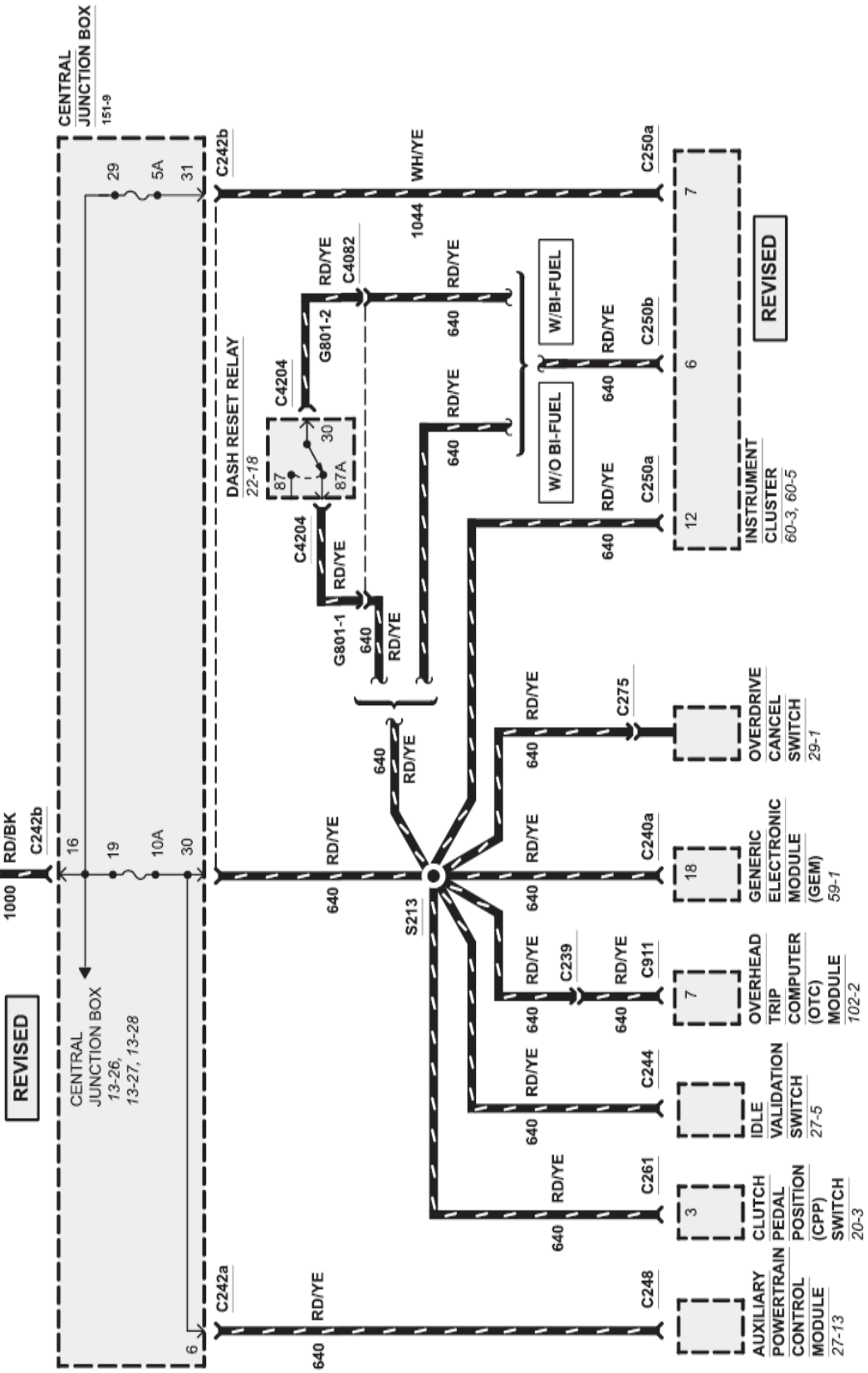

# POWER DISTRIBUTION 13-26

2001 EXCURSION, SUPER DUTY SERIES F-250, F-350, F-450, F-550

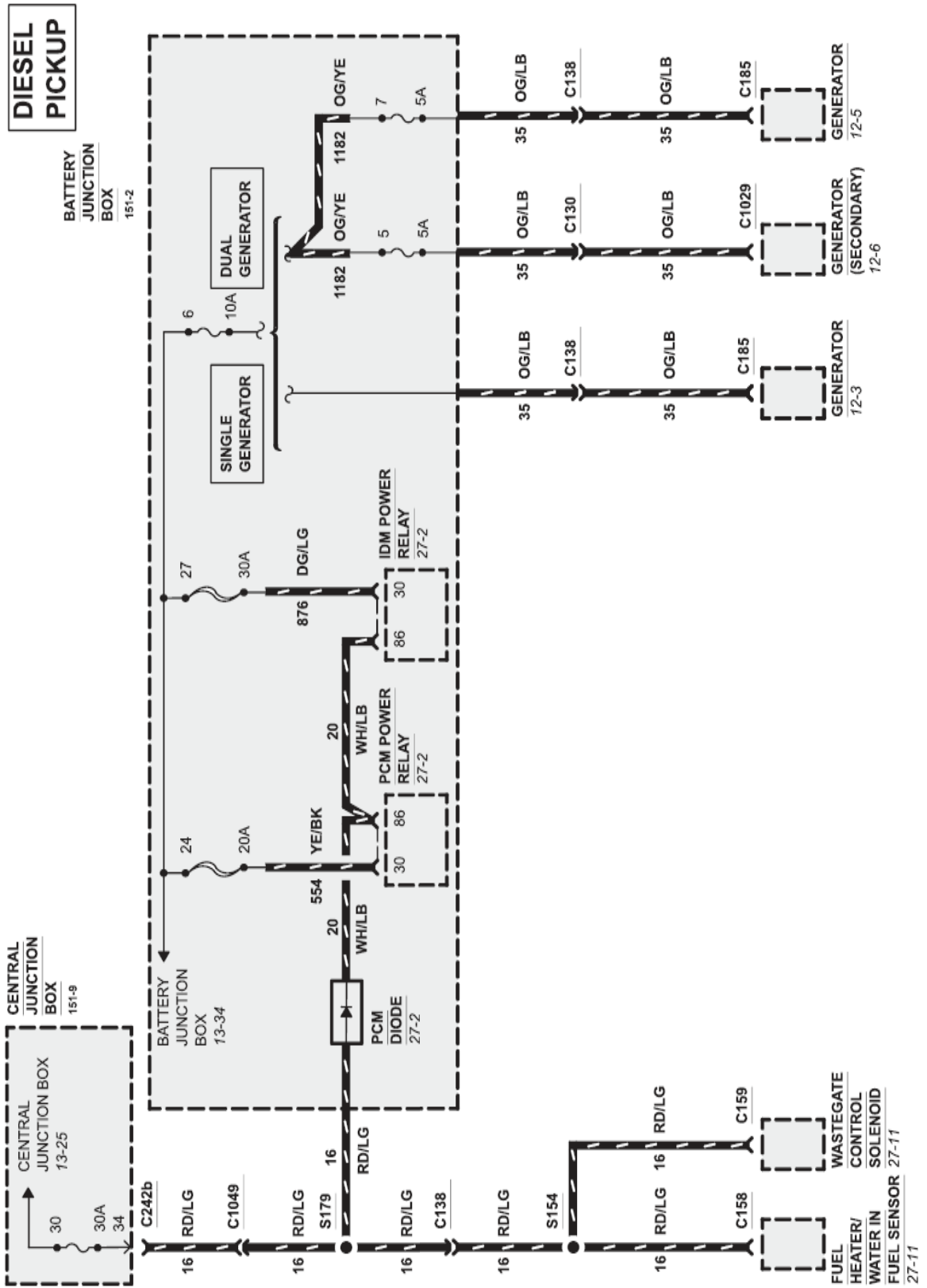

# 13-27 POWER DISTRIBUTION

2001 EXCURSION, SUPER DUTY SERIES F-250, F-350, F-450, F-550

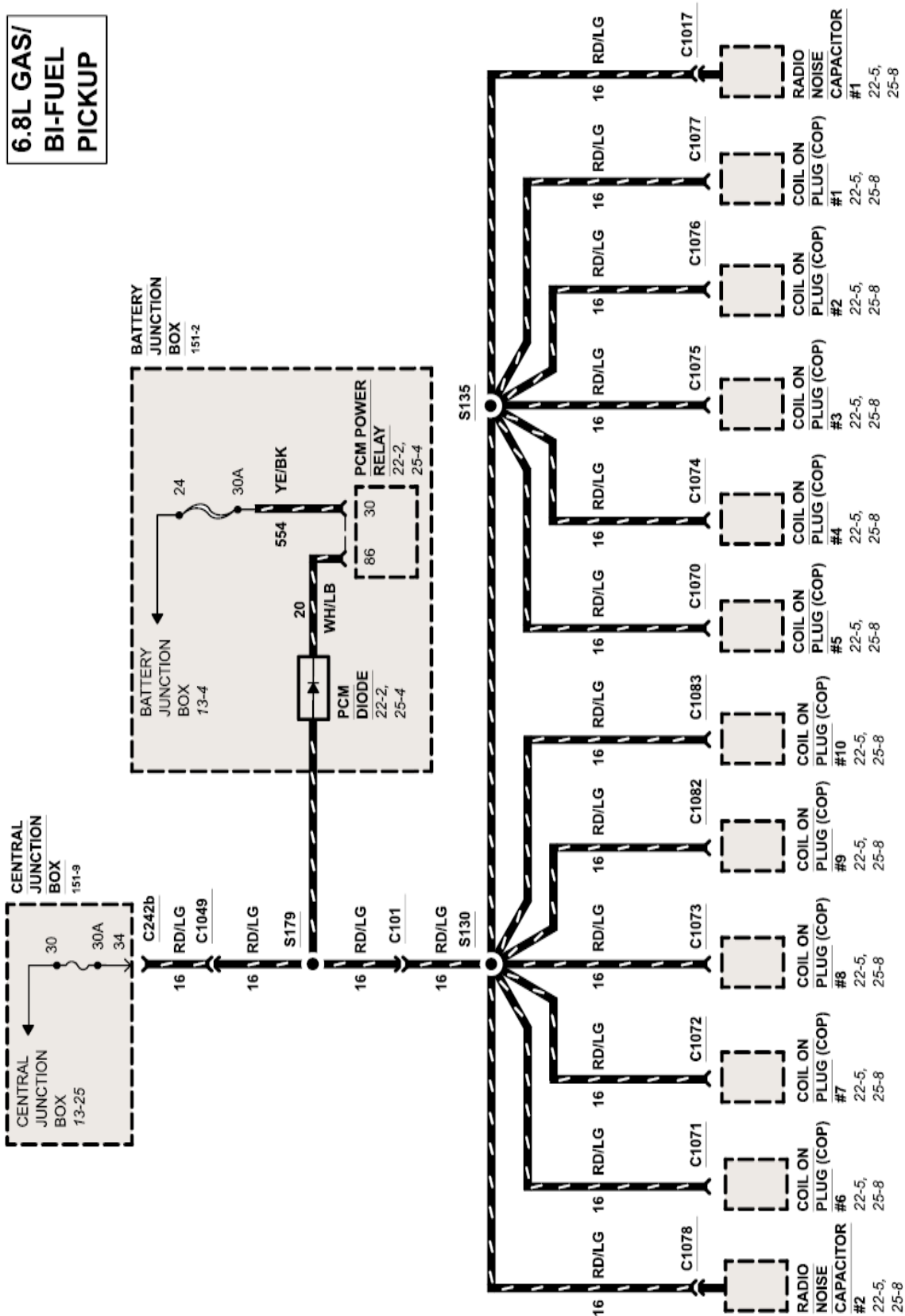

# POWER DISTRIBUTION 13-28

2001 EXCURSION, SUPER DUTY SERIES F-250, F-350, F-450, F-550

**5.4L GAS PICKUP**

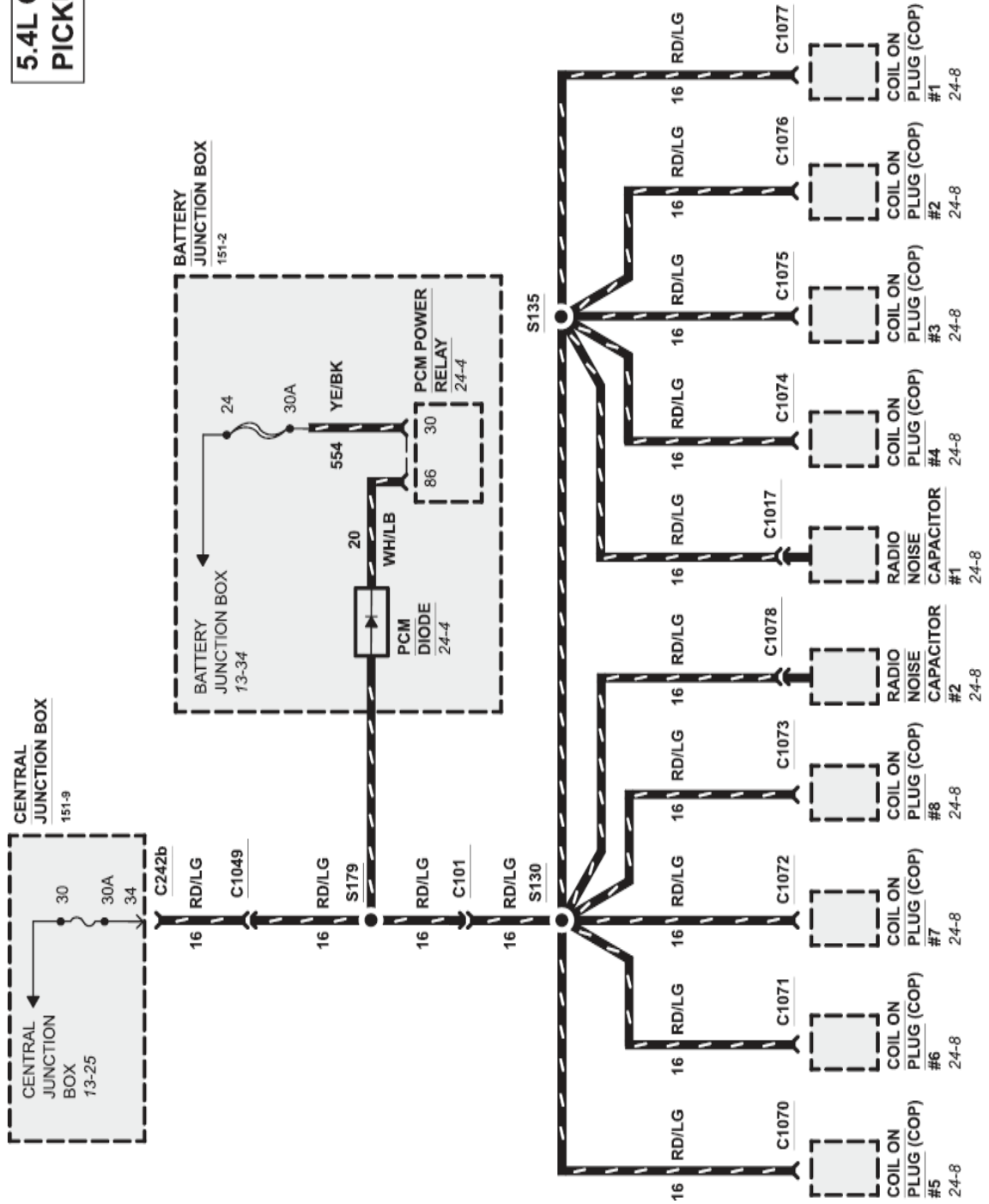

# 13-29 POWER DISTRIBUTION

2001 EXCURSION, SUPER DUTY SERIES F-250, F-350, F-450, F-550

PICKUP

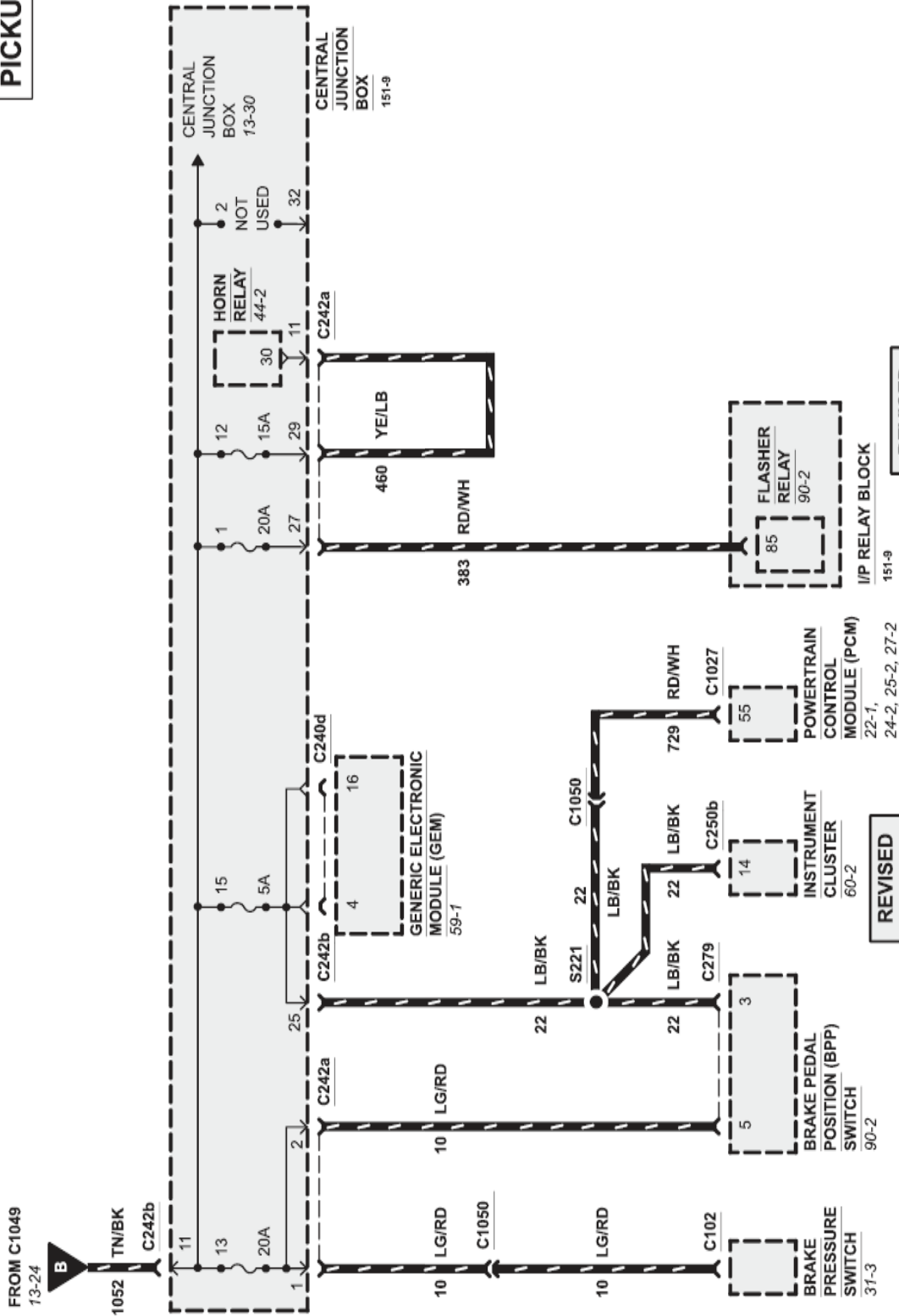

REVISÉ

151-9

REVISÉ

# POWER DISTRIBUTION 13-30

2001 EXCURSION, SUPER DUTY SERIES F-250, F-350, F-450, F-550

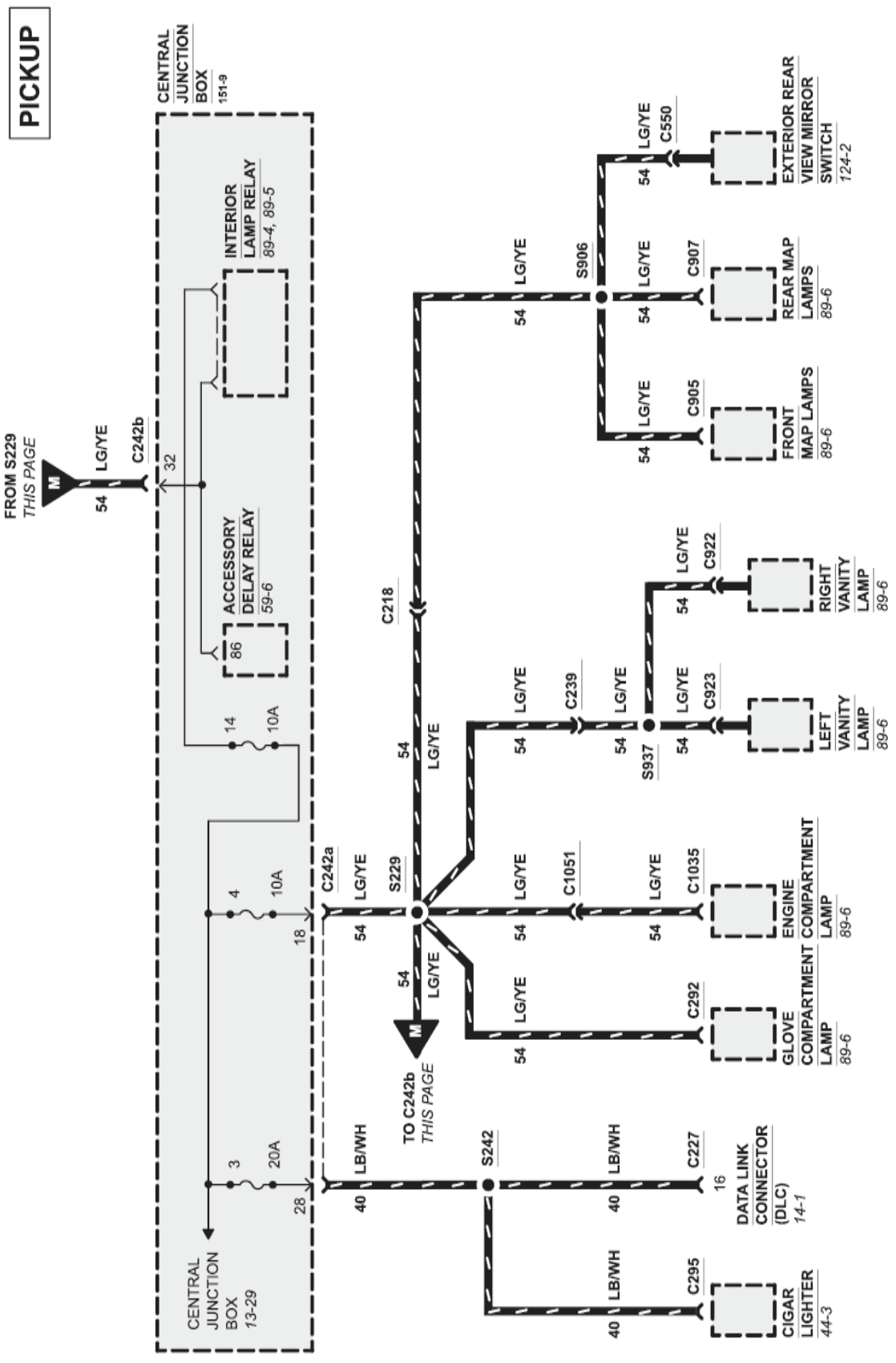

# 13-31 POWER DISTRIBUTION

2001 EXCURSION, SUPER DUTY SERIES F-250, F-350, F-450, F-550

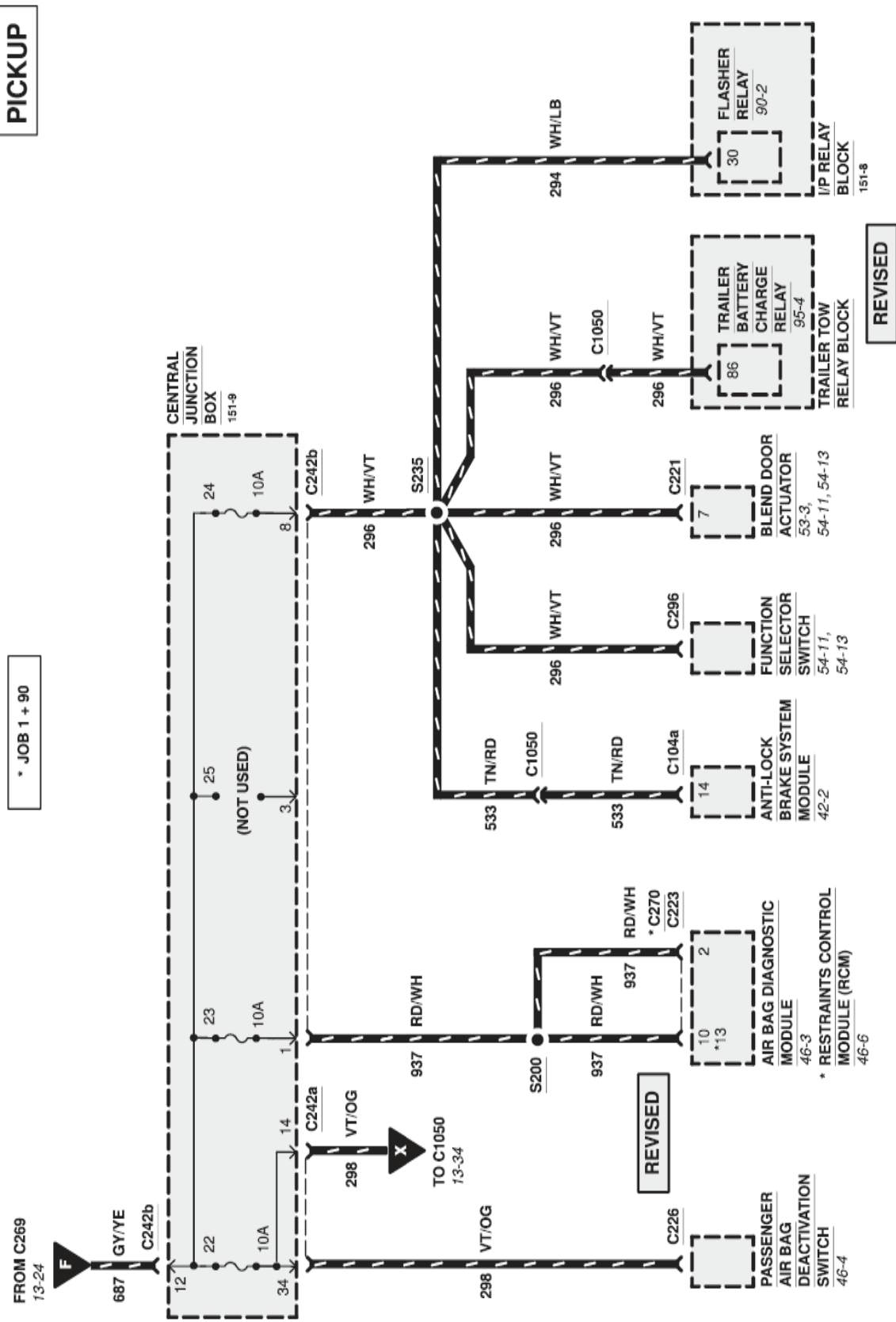

# POWER DISTRIBUTION 13-32

2001 EXCURSION, SUPER DUTY SERIES F-250, F-350, F-450, F-550

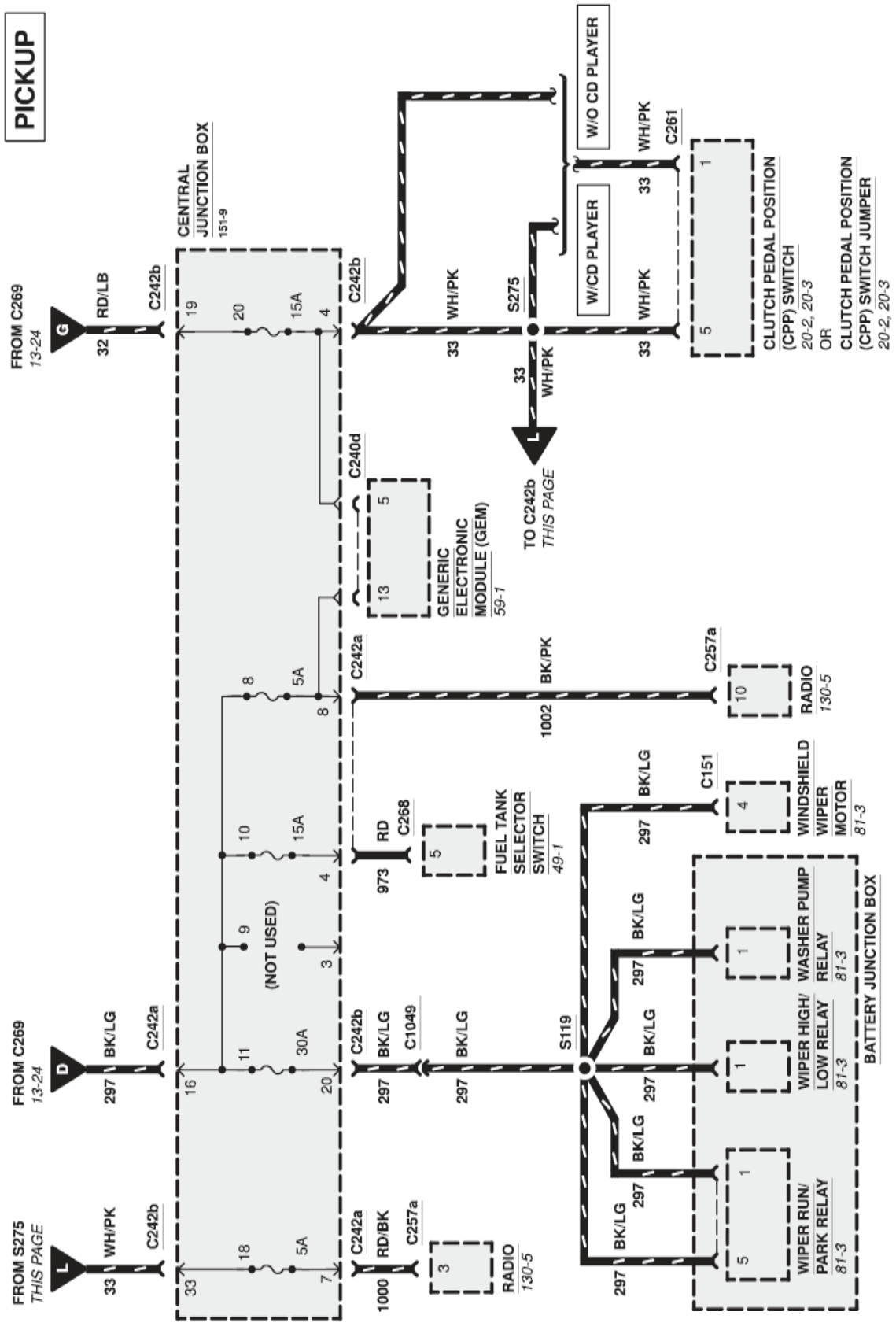





# POWER DISTRIBUTION 13-34

2001 EXCURSION, SUPER DUTY SERIES F-250, F-350, F-450, F-550

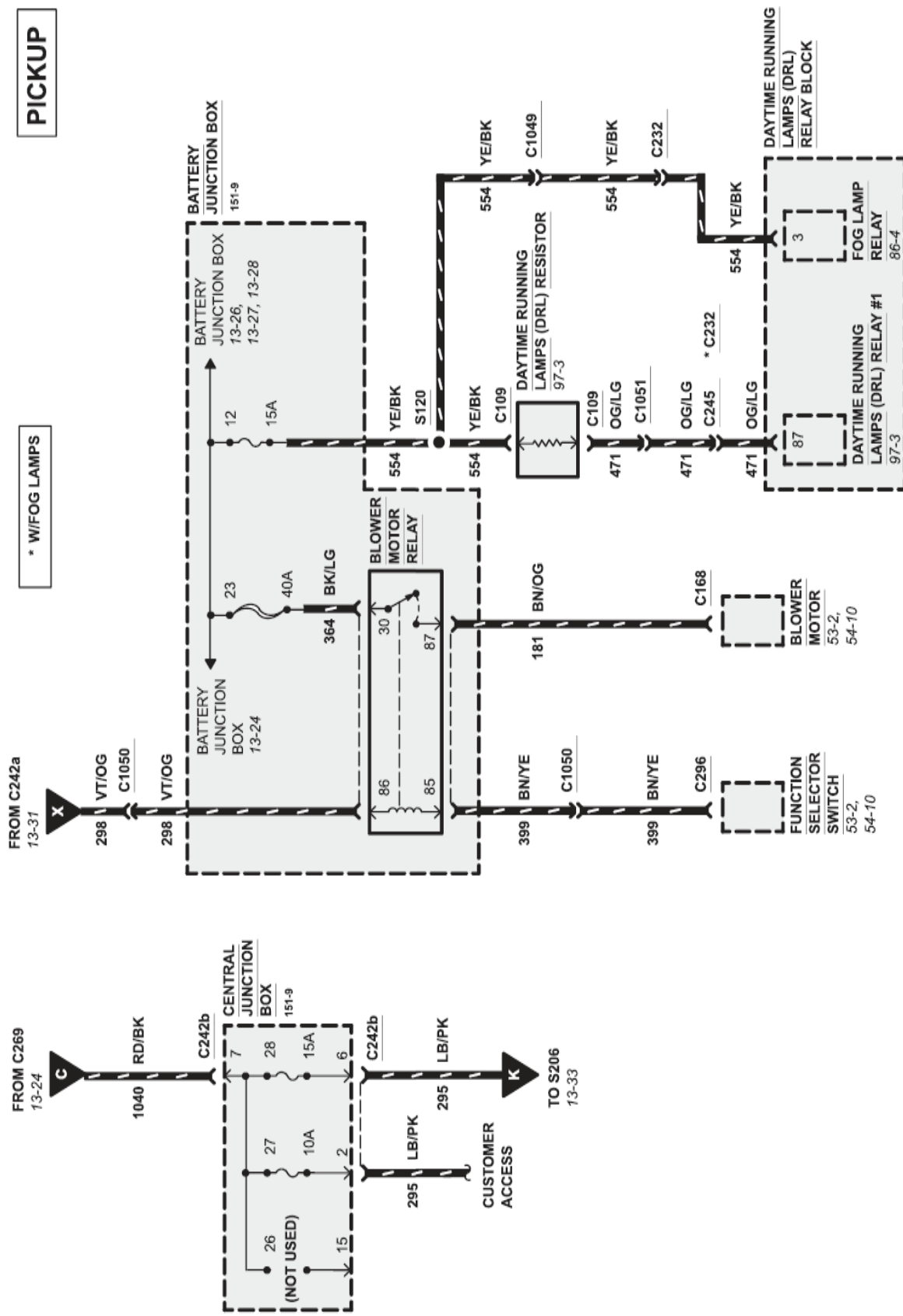

\* W/FOG LAMPS

PICKUP

