

### Component Location

### Engine Mounted Components, F-Series 250/550, Excursion and E-Series

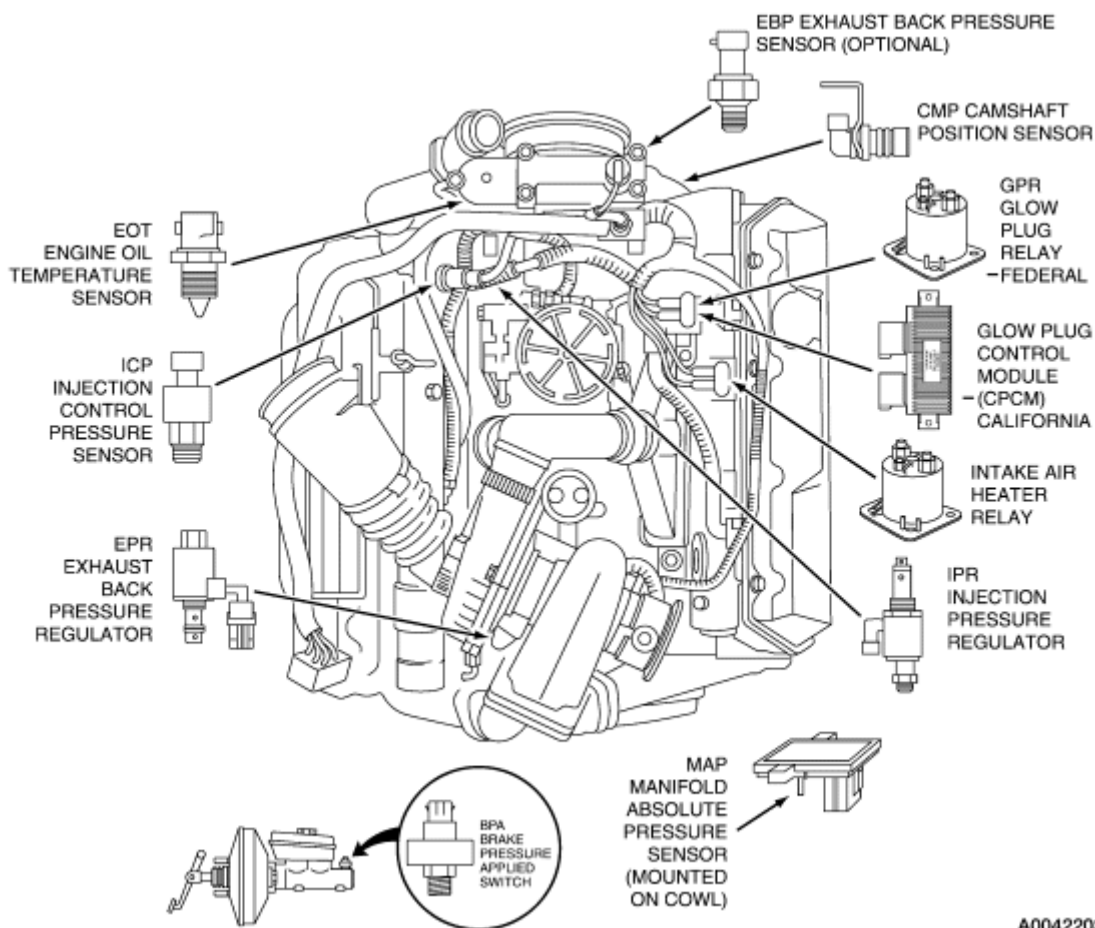

A0042203

### Engine Mounted Components, F-Series 650/750

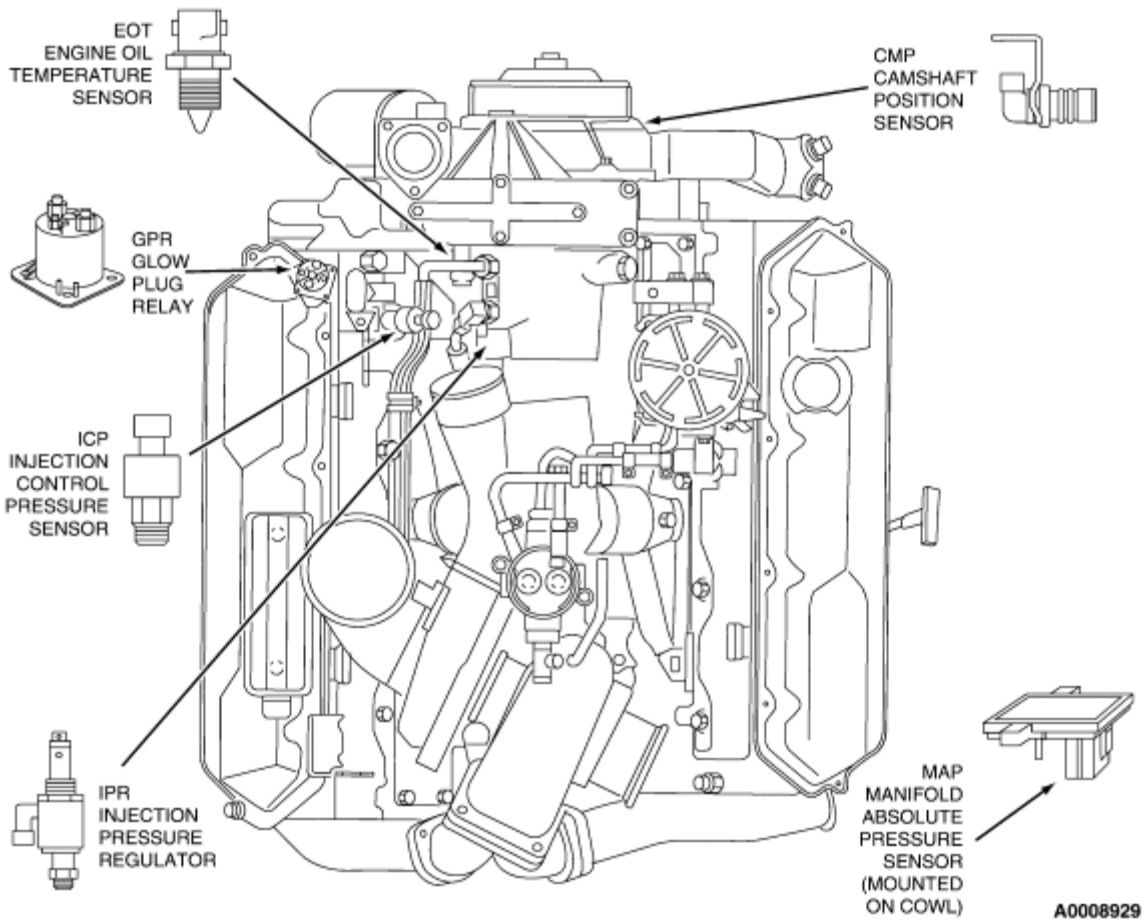

### Switch Location

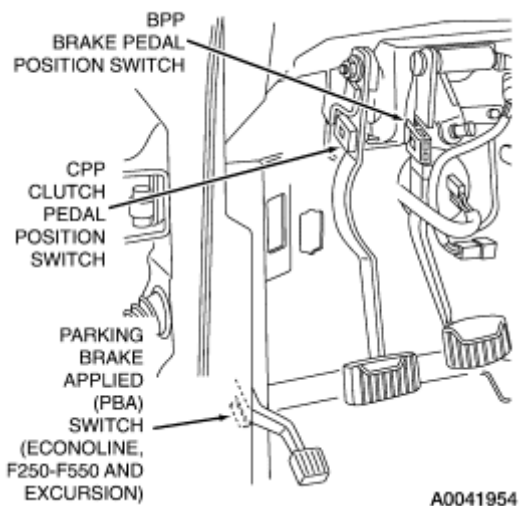

### Barometric Pressure (BARO) Sensor

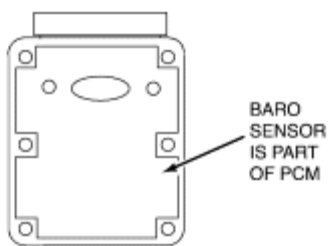

A0011109

### Switch Location — E-Series

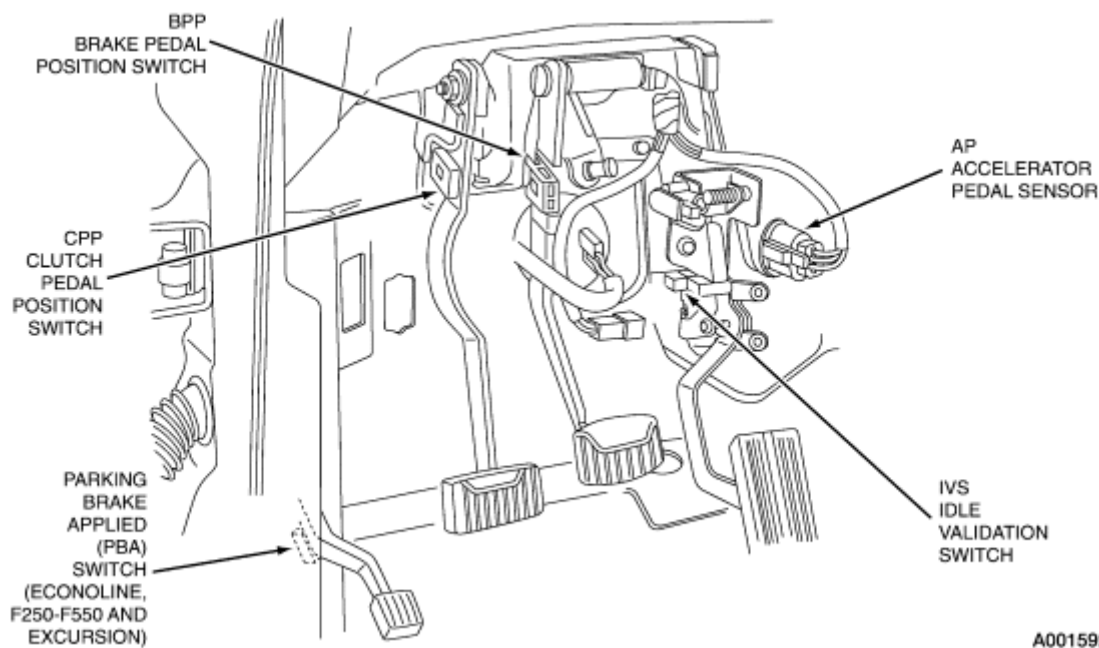

A0015927

### Switch Location — Parking Brake Applied (PBA) Switch, F-Series650/750

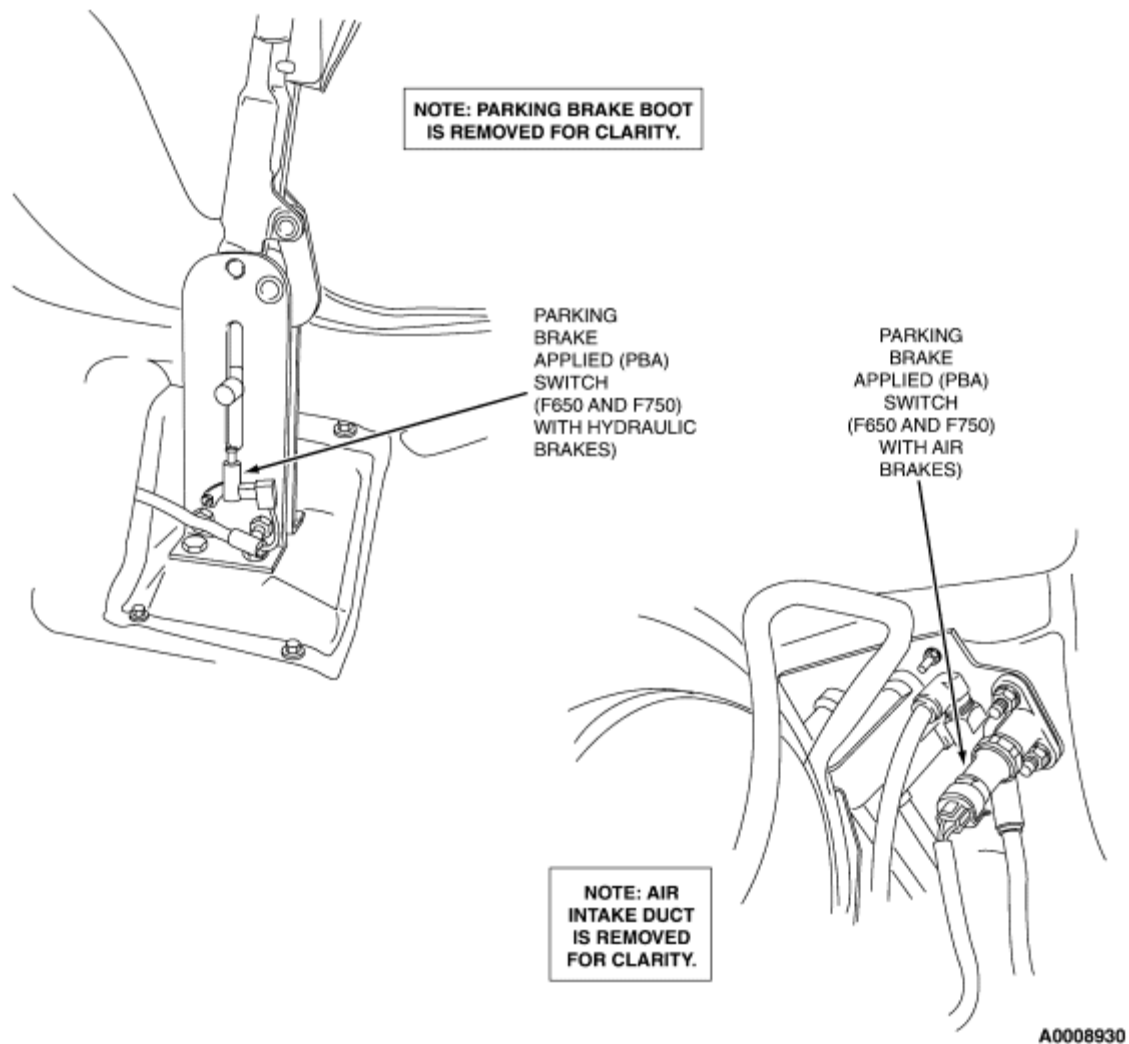

### Downshift Solenoid — F-Series 650/750 with Allison AT545 Automatic Transmission

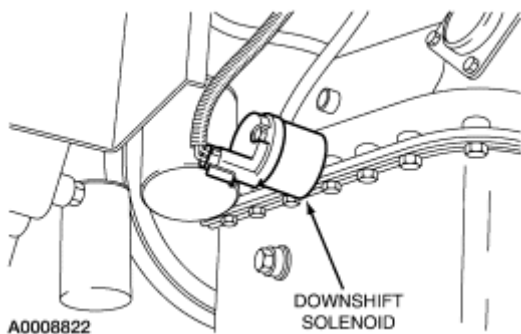

### Brake Pressure Applied Switch — F-Series 650/750 with Hydraulic Brakes

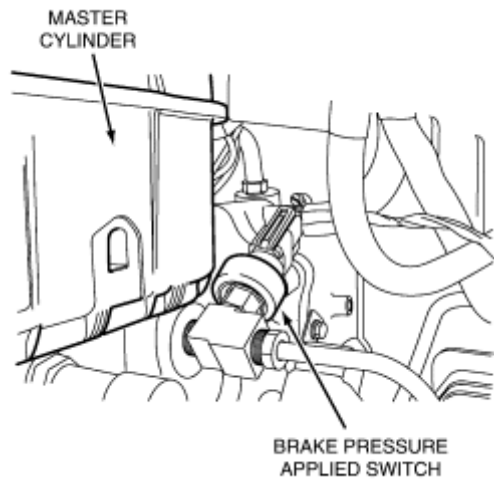

A0028752

### Brake Pressure Applied Switch — F-Series 650/750 with Air Brakes

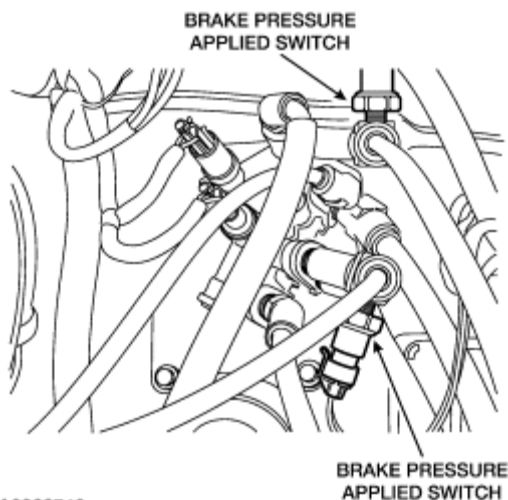

A0028746

### Electronic Throttle Control — F-650/750

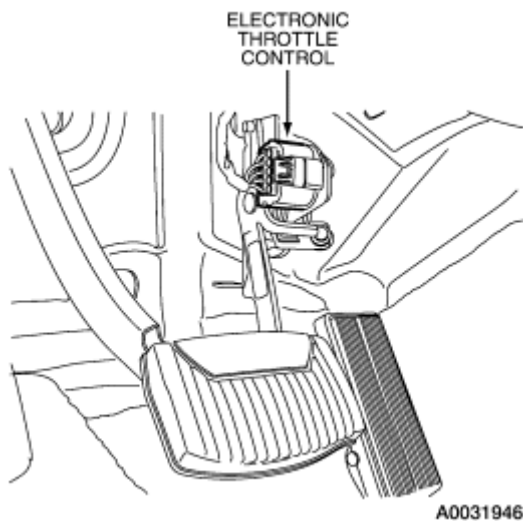

A0031946

### Electronic Throttle Control — F-Series/Excursion

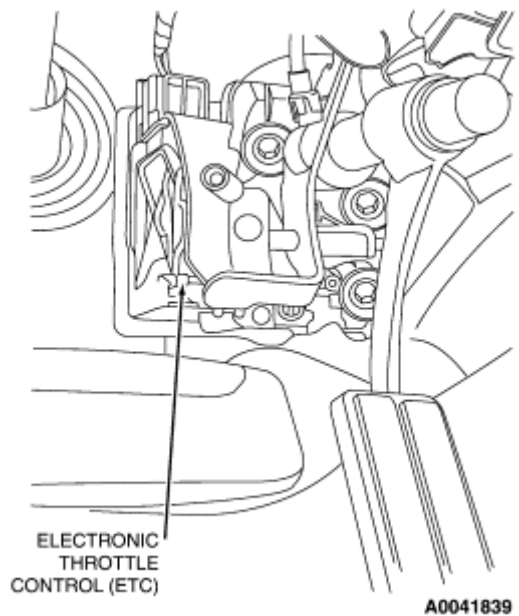

### Boost Control Solenoid

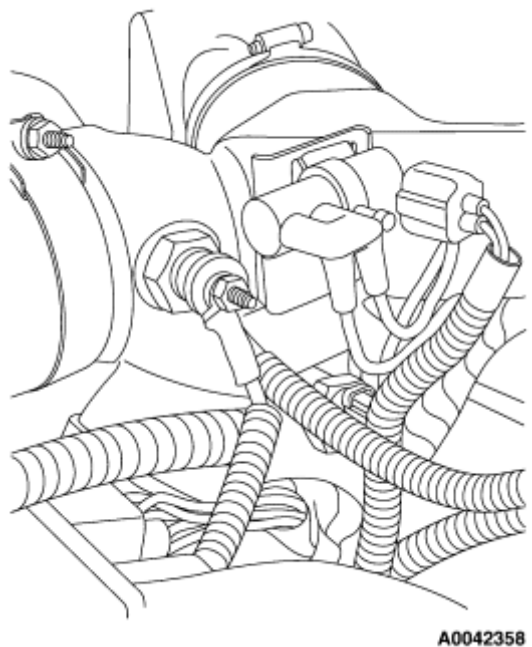

### Relays — F-Series 650/750

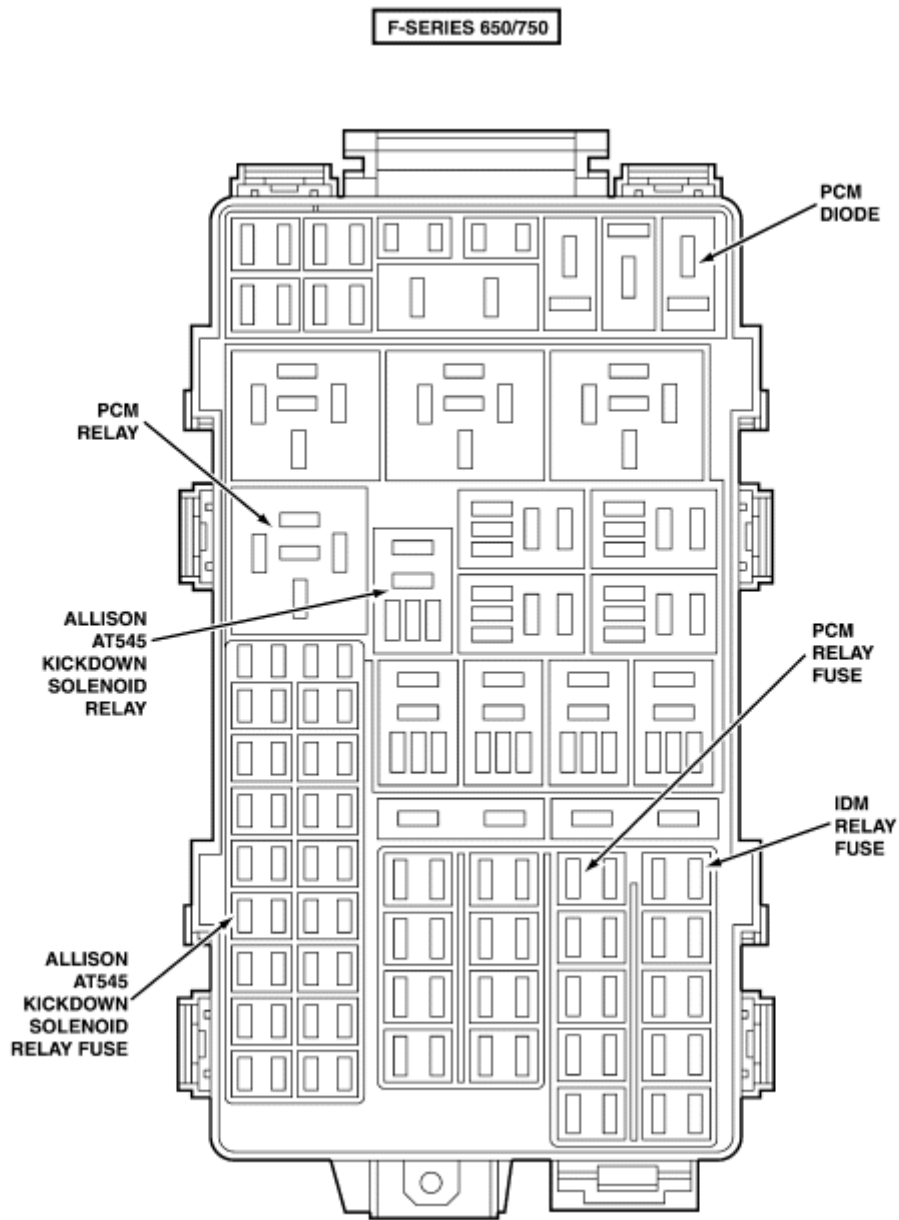

A0042898

### Neutral Switch — F-Series 650/750 with Allison Transmission

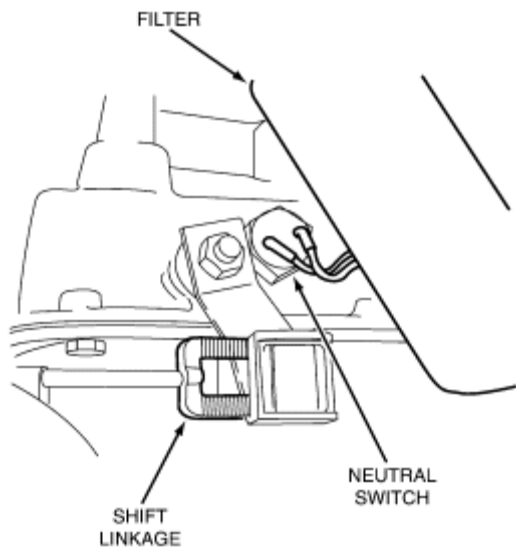

A0008943

### Injector Drive Module (IDM) Relay, F-Series 650/750

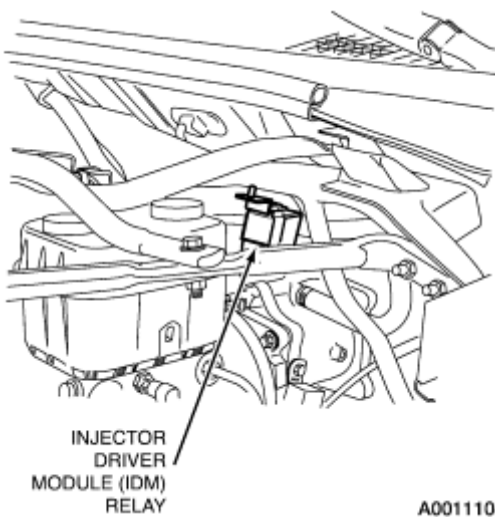

A0011108



